

SITE PLAN





LEGEND

1ST STOREY

- 1 ARRIVAL DROP OFF
- 2 CASCADING GARDEN
- 3 FUNCTION ROOM
- 4 OUTDOOR TERRACE
- 5 SAUNA & CHANGING ROOM
- 6 GYM
- 7 YOGA DECK
- 8 50M LAP POOL
- 9 SUN LOUNGERS
- 10 FLOATING PAVILLION
- 11 CHILDREN'S SWIMMING POOL
- 12 JACUZZI
- 13 LAWN
- 14 PLAYGROUND
- 15 BBQ PAVILION
- 16 RECREATIONAL TENNIS COURT
- 17 READING COVE
- 18 SHOP
- 19 PINE FOREST
- 20 BICYCLE PARKING FOR PUBLIC
- 21 FLORAL ALLEY
- 22 SPRING GARDEN
- 23 SUMMER GARDEN
- 24 JOGGING PATH
- 25 FITNESS CORNER
- 26 RESTING CORNER
- 27 FOOT REFLEXOLOGY CORNER
- 28 MEDITATION CORNER
- 29 OUTDOOR LIVING CORNER
- 30 COMMUNITY GARDENING

ROOF LEVEL

- 31 ROOF TERRACES AT 101, 103, 107, 109, 111, 117

BASEMENT 1

- A SPRINKLER PUMP ROOM
- B OUTDOOR GENSET

OTHERS

- C GUARD HOUSE
- D BIN CENTRE
- E SUBSTATION
- F SIDE GATES

SITEPLAN

Click on the unit number to access the floorplan directly

Unit Type	Size (sq ft)
1 BEDROOM	441-463
1+STUDY	495-506
2 BEDROOM	689-700
2+STUDY	689
3 BEDROOM	936/1066/1087
4 BEDROOM	1410
4 BR PENTHOUSE	1668/1776/2088
5 BR+S PENTHOUSE	2486

Click here to navigate to Penthouse floorplan



LEGEND

1ST STOREY

- 1 ARRIVAL DROP OFF
- 2 CASCADING GARDEN
- 3 FUNCTION ROOM
- 4 OUTDOOR TERRACE
- 5 SAUNA & CHANGING ROOM
- 6 GYM
- 7 YOGA DECK
- 8 50M LAP POOL
- 9 SUN LOUNGERS
- 10 FLOATING PAVILLION
- 11 CHILDREN'S SWIMMING POOL
- 12 JACUZZI
- 13 LAWN
- 14 PLAYGROUND
- 15 BBQ PAVILION
- 16 RECREATIONAL TENNIS COURT
- 17 READING COVE
- 18 SHOP
- 19 PINE FOREST
- 20 BICYCLE PARKING FOR PUBLIC
- 21 FLORAL ALLEY
- 22 SPRING GARDEN
- 23 SUMMER GARDEN
- 24 JOGGING PATH
- 25 FITNESS CORNER
- 26 RESTING CORNER
- 27 FOOT REFLEXOLOGY CORNER
- 28 MEDITATION CORNER
- 29 OUTDOOR LIVING CORNER
- 30 COMMUNITY GARDENING

ROOF LEVEL

- 31 ROOF TERRACES AT 101, 103, 107, 109, 111, 117

BASEMENT 1

- A SPRINKLER PUMP ROOM
- B OUTDOOR GENSET

OTHERS

- C GUARD HOUSE
- D BIN CENTRE
- E SUBSTATION
- F SIDE GATES



All areas stated are estimated and subject to final survey

UNIT DISTRIBUTION CHART

101 TAMPINES ST 86 S(528575)

Unit	01	02	03	04
15				
14				
13				
12				
11				
10			B1	C2
9	B3	B2	B1	C2
8	B3	B2	B1	C2
7	B3	B2	B1	C2
6	B3	B2	B1	C2
5	B3	B2	B1	C2
4	B3	B2	B1	C2
3	B3	B2	B1	C2
2	B3	B2	B1	C2
1	B3-P			C2-P

103 TAMPINES ST 86 S(528576)

Unit	05	08	06	07
15				
14				
13	PH4		C1	B1
12	D1	C2	C1	B1
11	D1	C2	C1	B1
10	D1	C2	C1	B1
9	D1	C2	C1	B1
8	D1	C2	C1	B1
7	D1	C2	C1	B1
6	D1	C2	C1	B1
5	D1	C2	C1	B1
4	D1	C2	C1	B1
3	D1	C2	C1	B1
2	D1	C2	C1	B1
1				

107 TAMPINES ST 86 S(528533)

Unit	13	14	15	16	17	18	19	20	21	22	23
15	PH1			B3	AS2	AS4	A2				
14	A1	AS2	B3	B3	AS2	AS4	A2	A2			
13	A1	AS2	B3	B3	AS2	AS4	A2	A2	AS4	AS2	
12	A1	AS2	B3	B3	AS2	AS4	A2	A2	AS4	AS2	
11	A1	AS2	B3	B3	AS2	AS4	A2	A2	AS4	AS2	B2
10	A1	AS2	B3	B3	AS2	AS4	A2	A2	AS4	AS2	B2
9	A1	AS2	B3	B3	AS2	AS4	A2	A2	AS4	AS2	B2
8	A1	AS2	B3	B3	AS2	AS4	A2	A2	AS4	AS2	B2
7	A1	AS2	B3	B3	AS2	AS4	A2	A2	AS4	AS2	B2
6	A1	AS2	B3	B3	AS2	AS4	A2	A2	AS4	AS2	B2
5	A1	AS2	B3	B3	AS2	AS4	A2	A2	AS4	AS2	B2
4	A1	AS2	B3	B3	AS2	AS4	A2	A2	AS4	AS2	B2
3	A1	AS2	B3	B3	AS2	AS4	A2	A2	AS4	AS2	B2
2	A1	AS2	B3	B3	AS2	AS4	A2	A2	AS4	AS2	B2
1	A1-P	AS2-P	B3-P	B3-P	AS2-P	AS4-P	A2-P	A2-P	AS4-P	AS2-P	B2-P

111 TAMPINES ST 86 S(528535)

Unit	34	37	35	36
15				
14				
13				
12	PH4		C1	B1
11	D1	C2	C1	B1
10	D1	C2	C1	B1
9	D1	C2	C1	B1
8	D1	C2	C1	B1
7	D1	C2	C1	B1
6	D1	C2	C1	B1
5	D1	C2	C1	B1
4	D1	C2	C1	B1
3	D1	C2	C1	B1
2	D1	C2	C1	B1
1	D1-P	C2-P	C1-P	B1-P

113 TAMPINES ST 86 S(528536)

Unit	38	39	40	41	
15	PH2			B4	C3
14	C1	BS1	B4	C3	
13	C1	BS1	B4	C3	
12	C1	BS1	B4	C3	
11	C1	BS1	B4	C3	
10	C1	BS1	B4	C3	
9	C1	BS1	B4	C3	
8	C1	BS1	B4	C3	
7	C1	BS1	B4	C3	
6	C1	BS1	B4	C3	
5	C1	BS1	B4	C3	
4	C1	BS1	B4	C3	
3	C1	BS1	B4	C3	
2	C1	BS1	B4	C3	
1	C1-P	BS1-P	B4-P	C3-P	

105 TAMPINES ST 86 S(528577)

Level	Unit	09	10	11	12
15		PH2		B4	C3
14		C1	BS1	B4	C3
13		C1	BS1	B4	C3
12		C1	BS1	B4	C3
11		C1	BS1	B4	C3
10		C1	BS1	B4	C3
9		C1	BS1	B4	C3
8		C1	BS1	B4	C3
7		C1	BS1	B4	C3
6		C1	BS1	B4	C3
5		C1	BS1	B4	C3
4		C1	BS1	B4	C3
3		C1	BS1	B4	C3
2		C1	BS1	B4	C3
1				B4-P	C3-P

LEGEND

	1 - BEDROOM 1 - BEDROOM + STUDY
	2 - BEDROOM 2 - BEDROOM + STUDY
	3 - BEDROOM
	4 - BEDROOM
	PENTHOUSE (4 - BEDROOM) PENTHOUSE (5 - BEDROOM + STUDY)

Level	Unit	24	25	26	27	28	29
							AS1
					AS1	AS3	AS1
			AS2	A1	AS1	AS3	AS1
			AS2	A1	AS1	AS3	AS1
	B2	AS2	A1	AS1	AS1	AS3	AS1
	B2	AS2	A1	AS1	AS1	AS3	AS1
	B2	AS2	A1	AS1	AS1	AS3	AS1
	B2	AS2	A1	AS1	AS1	AS3	AS1
	B2	AS2	A1	AS1	AS1	AS3	AS1
	B2	AS2	A1	AS1	AS1	AS3	AS1
	B2	AS2	A1	AS1	AS1	AS3	AS1
	B2	AS2	A1	AS1	AS1	AS3	AS1
	B2	AS2	A1	AS1	AS1	AS3	AS1
	B2	AS2	A1	AS1	AS1	AS3	AS1
	B2-P	AS2-P	A1-P	AS1-P	AS1-P	AS3-P	AS1-P

109 TAMPINES ST 86 S(528534)

Level	Unit	30	31	32	33
15					
14					
13					
12					
11					
10				B1	C2
9	B3	B2	B1	B1	C2
8	B3	B2	B1	B1	C2
7	B3	B2	B1	B1	C2
6	B3	B2	B1	B1	C2
5	B3	B2	B1	B1	C2
4	B3	B2	B1	B1	C2
3	B3	B2	B1	B1	C2
2	B3	B2	B1	B1	C2
1	B3-P	B2-P	B1-P	B1-P	C2-P

115 TAMPINES ST 86 S(528537)

Level	Unit	42	45	43	44
15		PH3		BS1	
14		C2	C1	BS1	C1
13		C2	C1	BS1	C1
12		C2	C1	BS1	C1
11		C2	C1	BS1	C1
10		C2	C1	BS1	C1
9		C2	C1	BS1	C1
8		C2	C1	BS1	C1
7		C2	C1	BS1	C1
6		C2	C1	BS1	C1
5		C2	C1	BS1	C1
4		C2	C1	BS1	C1
3		C2	C1	BS1	C1
2		C2	C1	BS1	C1
1		C2-P	C1-P	BS1-P	C1-P

117 TAMPINES ST 86 S(528538)

Level	Unit	46	47	48	49
15					
14					
13		C2	BS1		
12		C2	BS1	B2	B3
11		C2	BS1	B2	B3
10		C2	BS1	B2	B3
9		C2	BS1	B2	B3
8		C2	BS1	B2	B3
7		C2	BS1	B2	B3
6		C2	BS1	B2	B3
5		C2	BS1	B2	B3
4		C2	BS1	B2	B3
3		C2	BS1	B2	B3
2		C2	BS1	B2	B3
1		C2-P	BS1-P	B2-P	B3-P

TYPE A1 & A1-P

1 - BEDROOM 41 sqm / 441 sqft

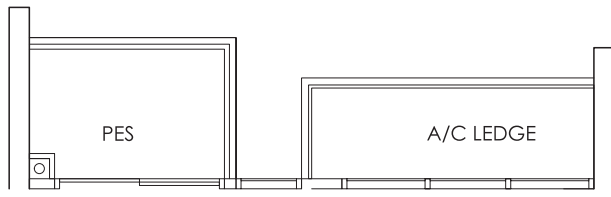

01-26
01-13*

A1-P

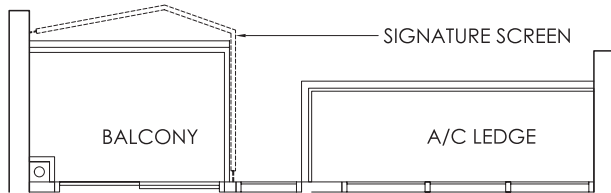

05-26
10-26

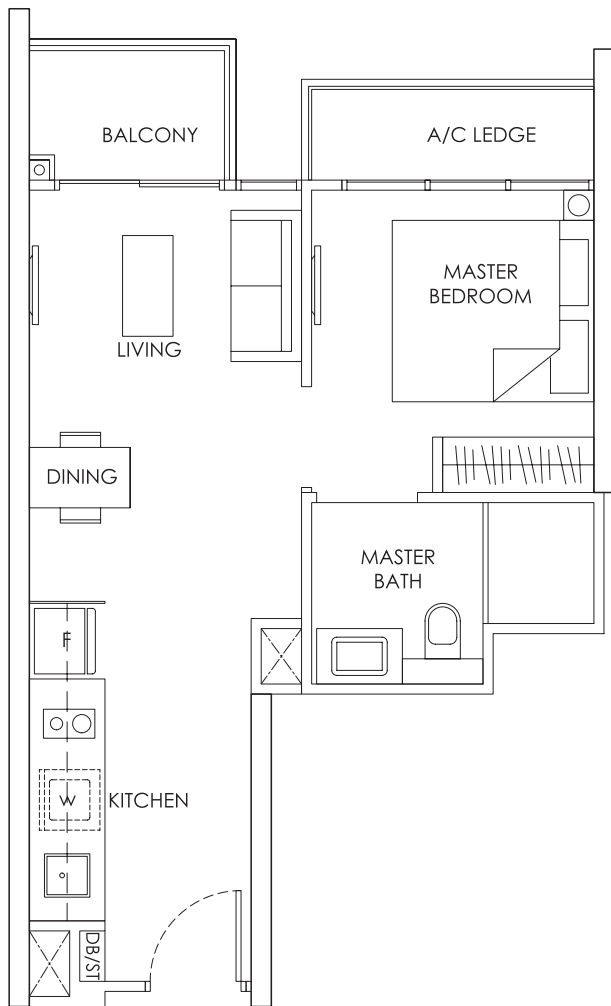

02-26 to 04-26
06-26 to 09-26
11-26 to 13-26

02-13* to 14-13*

mirror units *

A1

KEY PLAN

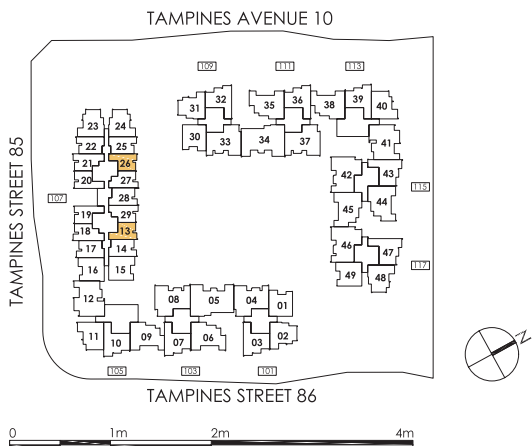

Area includes A/C ledge, balcony, PES, Roof Terrace and Void (where applicable). Orientation and facings will differ depending on the unit you are purchasing (please refer to key plan). All plans are not to scale and subject to changes as may be required by relevant authorities. All appliances and furniture shown in the plan are for illustration purpose only and not representation of fact. All floor areas are estimated and subjected to final survey.

- Legend: **F** - Fridge **DB/ST** - Distribution Board and Storage space
WC - Water Closet **W** - Washer cum Dryer **A/C** - Aircon
PES - Private Enclosed Space

TYPE A2 & A2-P

1 - BEDROOM 43 sqm / 463 sqft

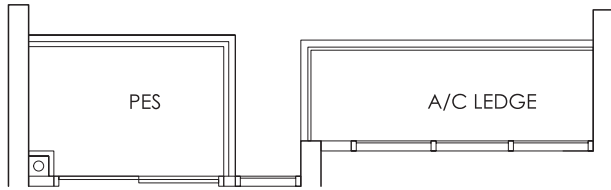

01-20
01-19*

A2-P

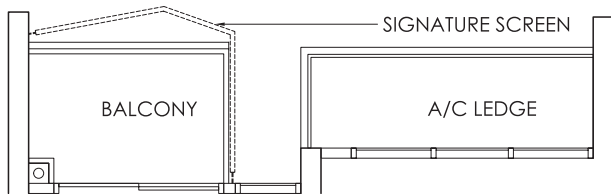

04-20
07-20
12-20

03-19*
07-19*
11-19*

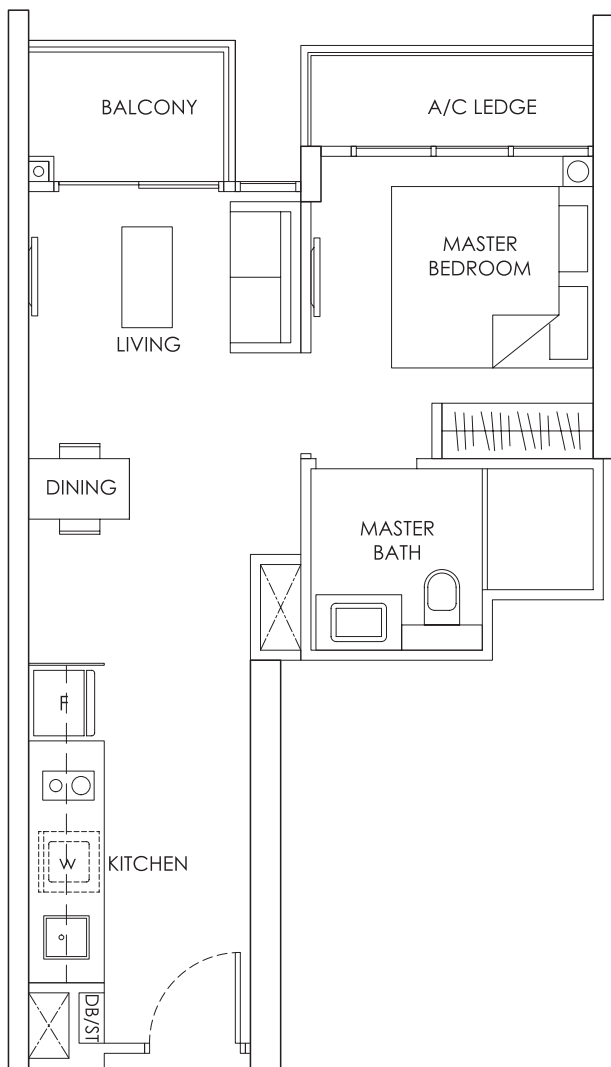

02-20, 03-20
05-20, 06-20
08-20 to 11-20
13-20, 14-20

02-19*
04-19* to 06-19*
08-19* to 10-19*
12-19* to 15-19*

mirror units *

A2

KEY PLAN

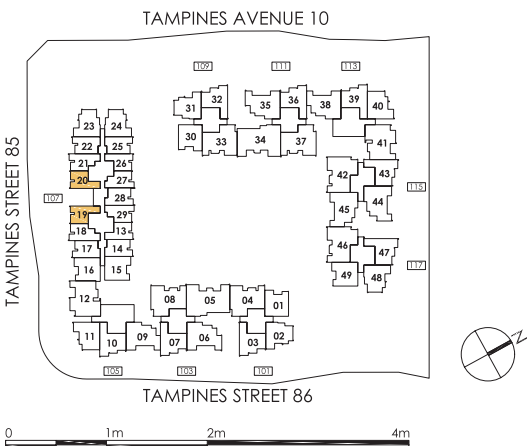

Area includes A/C ledge, balcony, PES, Roof Terrace and Void (where applicable). Orientation and facings will differ depending on the unit you are purchasing (please refer to key plan). All plans are not to scale and subject to changes as may be required by relevant authorities. All appliances and furniture shown in the plan are for illustration purpose only and not representation of fact. All floor areas are estimated and subjected to final survey.

Legend: F - Fridge DB/ST - Distribution Board and Storage space
WC - Water Closet W - Washer cum Dryer A/C - Aircon
PES - Private Enclosed Space

TYPE ASI & ASI-P

1 - BEDROOM + STUDY 46 sqm / 495 sqft

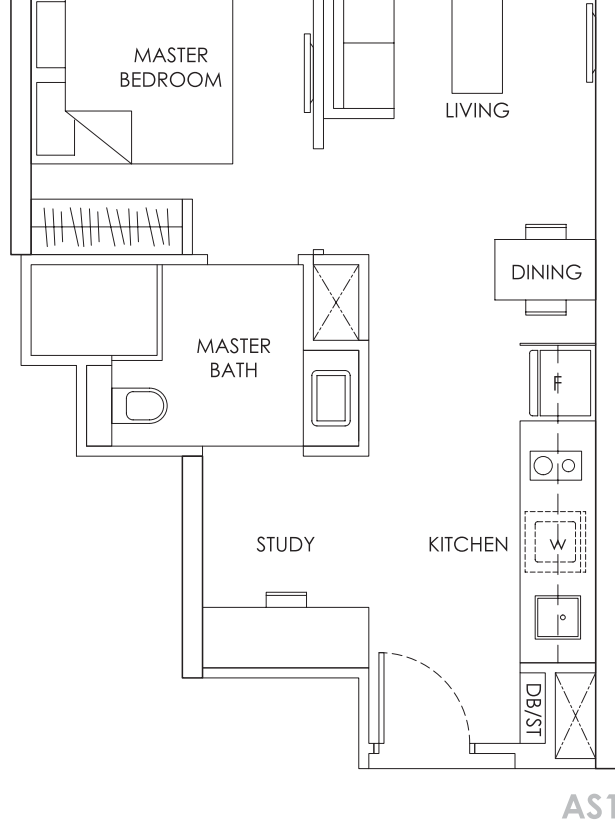
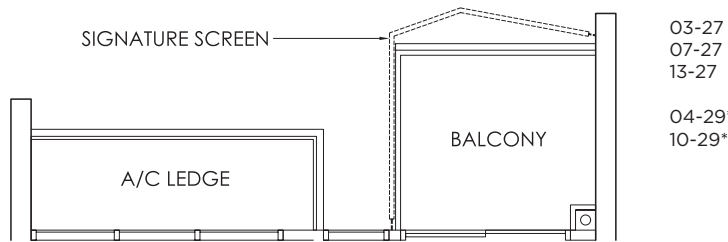
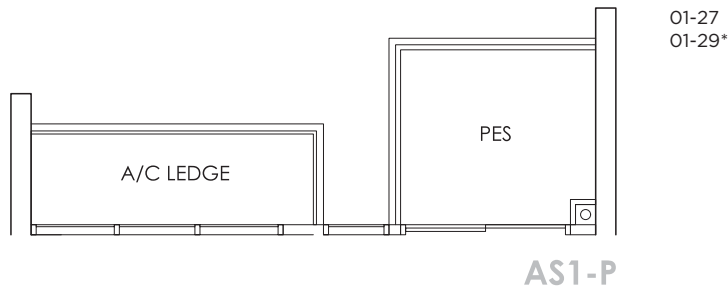

KEY PLAN

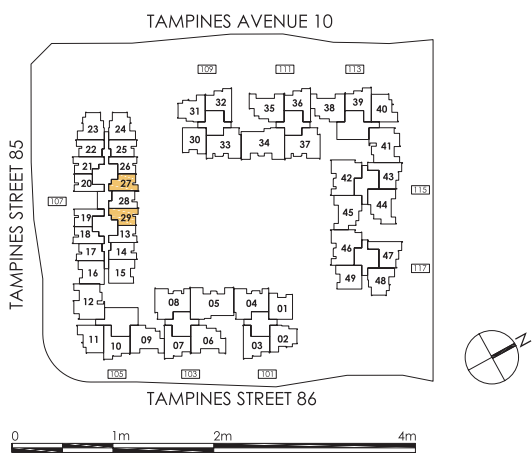

Area includes A/C ledge, balcony, PES, Roof Terrace and Void (where applicable). Orientation and facings will differ depending on the unit you are purchasing (please refer to key plan). All plans are not to scale and subject to changes as may be required by relevant authorities. All appliances and furniture shown in the plan are for illustration purpose only and not representation of fact. All floor areas are estimated and subjected to final survey.

- Legend: F - Fridge DB/ST - Distribution Board and Storage space
WC - Water Closet W - Washer cum Dryer A/C - Aircon
PES - Private Enclosed Space

TYPE AS2

1 - BEDROOM + STUDY 47 sqm / 506 sqft

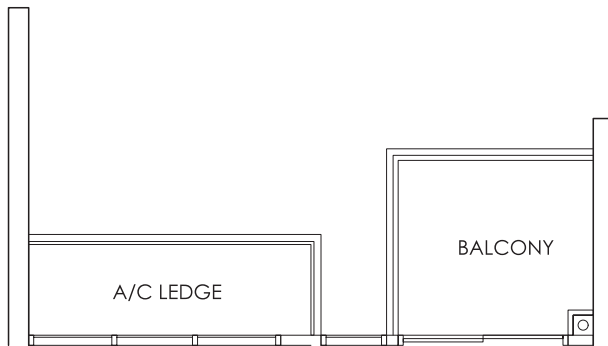

02-22 to 13-22
02-17* to 15-17*

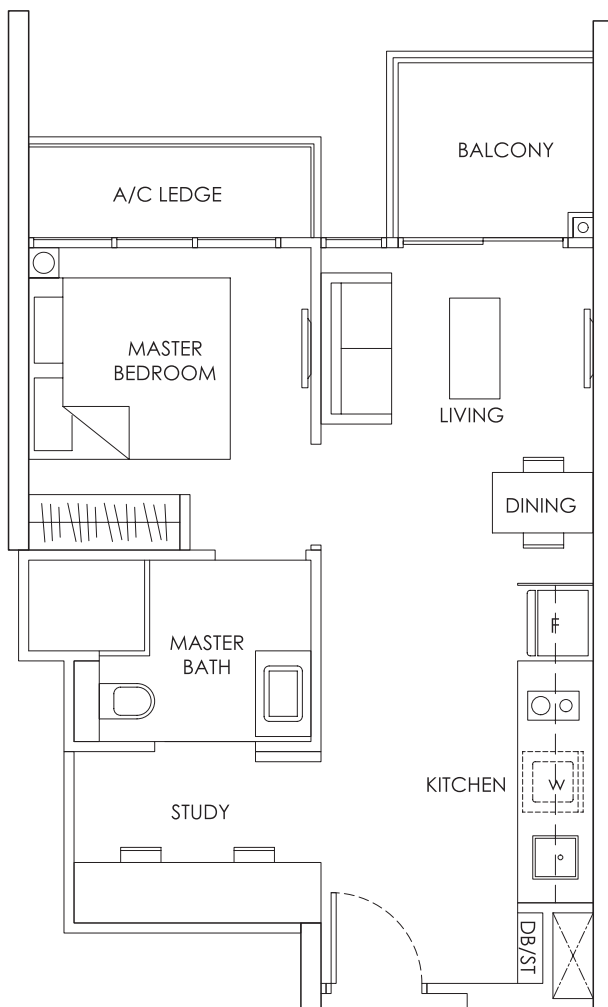

02-14 to 14-14
02-25* to 13-25*

mirror units *

KEY PLAN

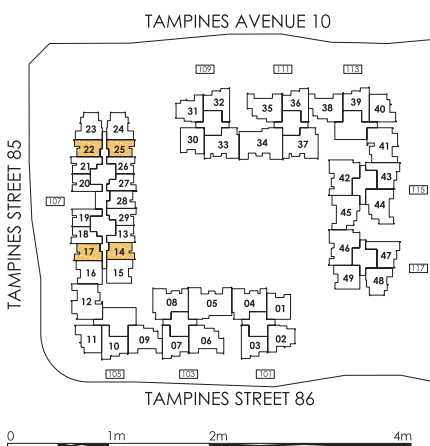

Area includes A/C ledge, balcony, PES, Roof Terrace and Void (where applicable). Orientation and facings will differ depending on the unit you are purchasing (please refer to key plan). All plans are not to scale and subject to changes as may be required by relevant authorities. All appliances and furniture shown in the plan are for illustration purpose only and not representation of fact. All floor areas are estimated and subjected to final survey.

Legend: F - Fridge DB/ST - Distribution Board and Storage space
WC - Water Closet W - Washer cum Dryer A/C - Aircon
PES - Private Enclosed Space

TYPE AS2-P

1 - BEDROOM + STUDY 47 sqm / 506 sqft

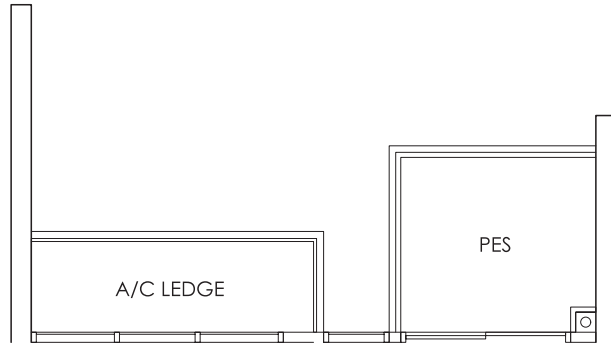

01-22
01-17*

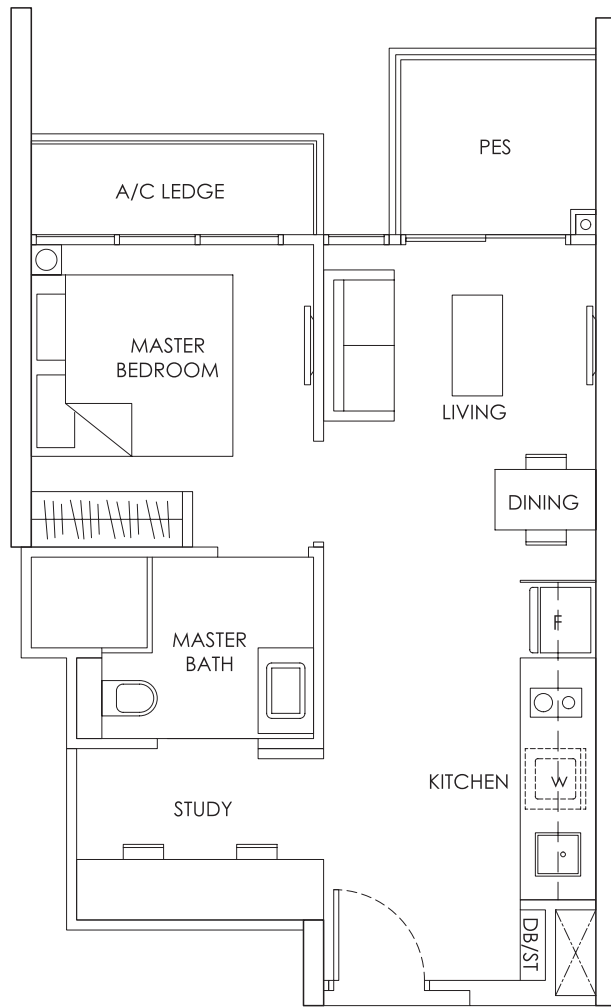

01-14
01-25*
mirror units *

1 - BEDROOM + STUDY

KEY PLAN

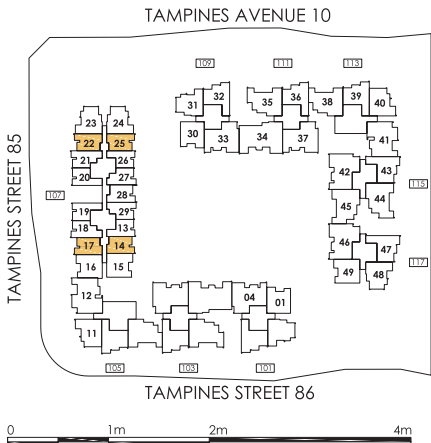

Area includes A/C ledge, balcony, PES, Roof Terrace and Void (where applicable). Orientation and facings will differ depending on the unit you are purchasing (please refer to key plan). All plans are not to scale and subject to changes as may be required by relevant authorities. All appliances and furniture shown in the plan are for illustration purpose only and not representation of fact. All floor areas are estimated and subjected to final survey.

Legend: F - Fridge DB/ST - Distribution Board and Storage space
WC - Water Closet W - Washer cum Dryer A/C - Aircon
PES - Private Enclosed Space

TYPE AS3 & AS3-P

1 - BEDROOM + STUDY 47 sqm / 506 sqft

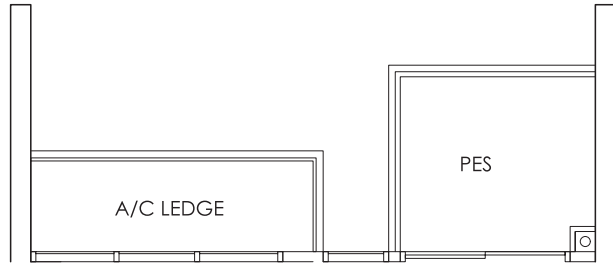

AS3-P

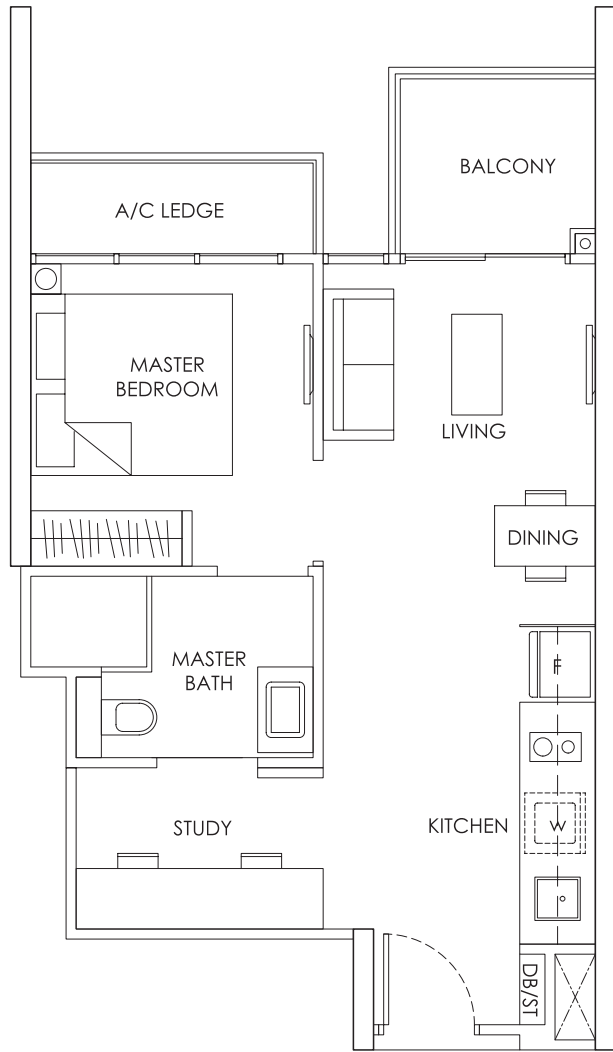

AS3

KEY PLAN

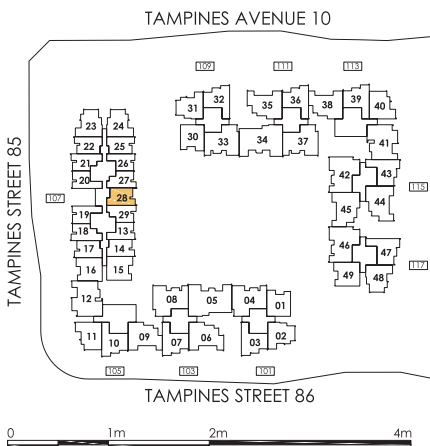

Area includes A/C ledge, balcony, PES, Roof Terrace and Void (where applicable). Orientation and facings will differ depending on the unit you are purchasing (please refer to key plan). All plans are not to scale and subject to changes as may be required by relevant authorities. All appliances and furniture shown in the plan are for illustration purpose only and not representation of fact. All floor areas are estimated and subjected to final survey.

- Legend: F - Fridge DB/ST - Distribution Board and Storage space
WC - Water Closet W - Washer cum Dryer A/C - Aircon
PES - Private Enclosed Space

TYPE AS4 & AS4-P

1 - BEDROOM + STUDY 47 sqm / 506 sqft

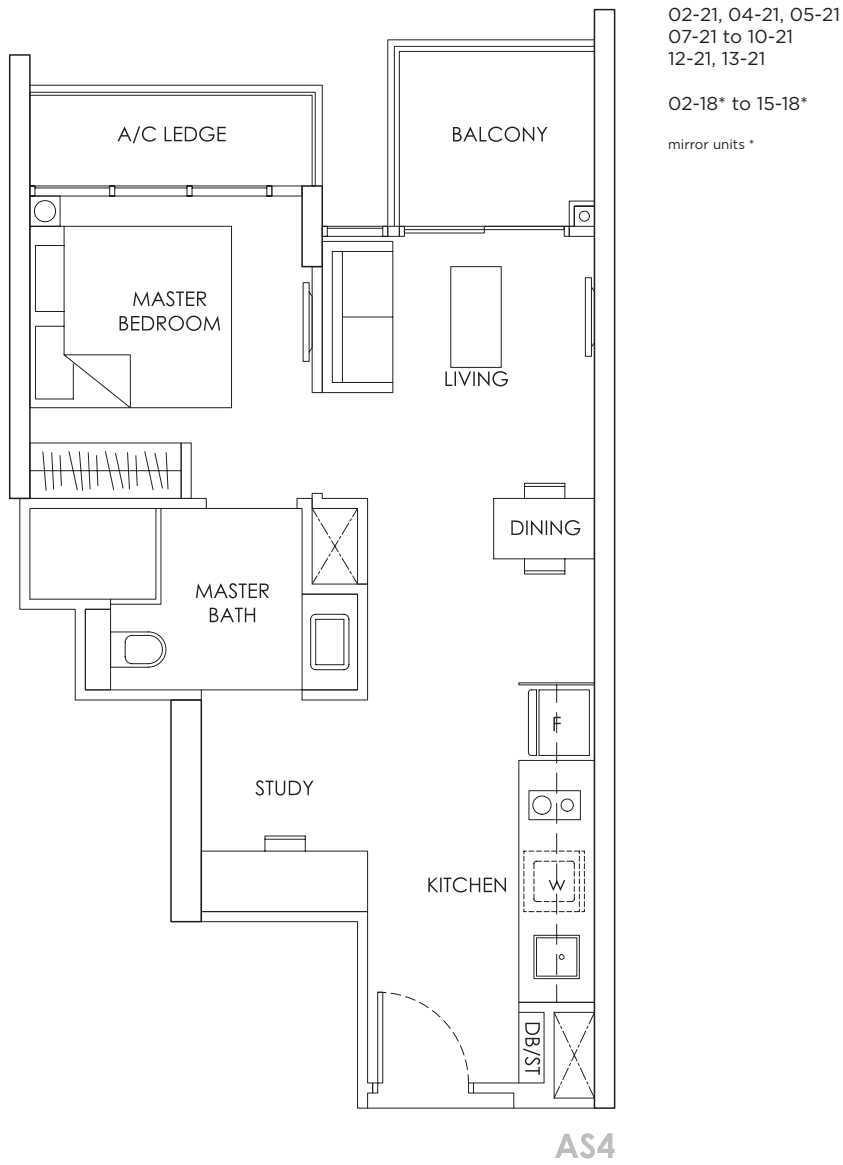
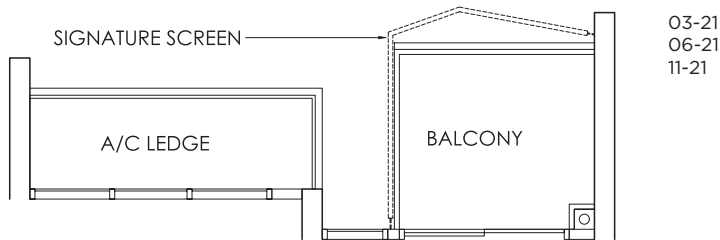
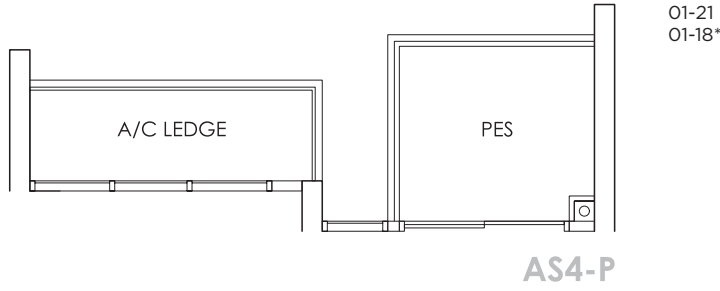

KEY PLAN

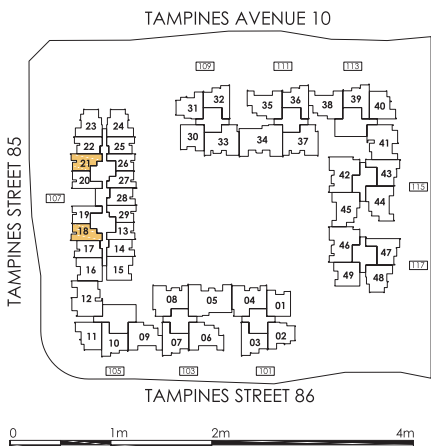

Area includes A/C ledge, balcony, PES, Roof Terrace and Void (where applicable). Orientation and facings will differ depending on the unit you are purchasing (please refer to key plan). All plans are not to scale and subject to changes as may be required by relevant authorities. All appliances and furniture shown in the plan are for illustration purpose only and not representation of fact. All floor areas are estimated and subjected to final survey.

Legend: F - Fridge DB/ST - Distribution Board and Storage space
WC - Water Closet W - Washer cum Dryer A/C - Aircon
PES - Private Enclosed Space

TYPE B1

2 - BEDROOM 64 sqm / 689 sqft

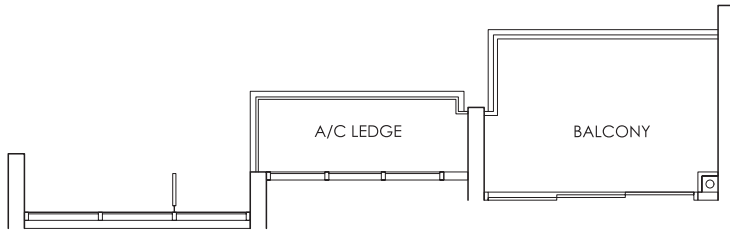

02-07, 07-07, 08-07, 09-07
02-36, 07-36, 08-36, 09-36

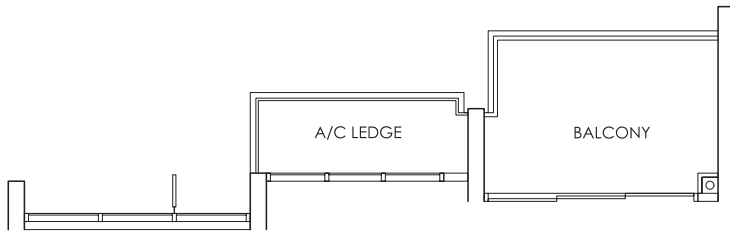

04-03, 06-03
04-32, 06-32, 07-32

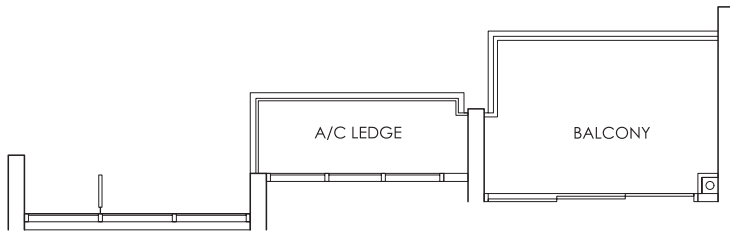

04-07, 05-07, 10-07, 11-07, 13-07
04-36, 05-36, 11-36, 12-36

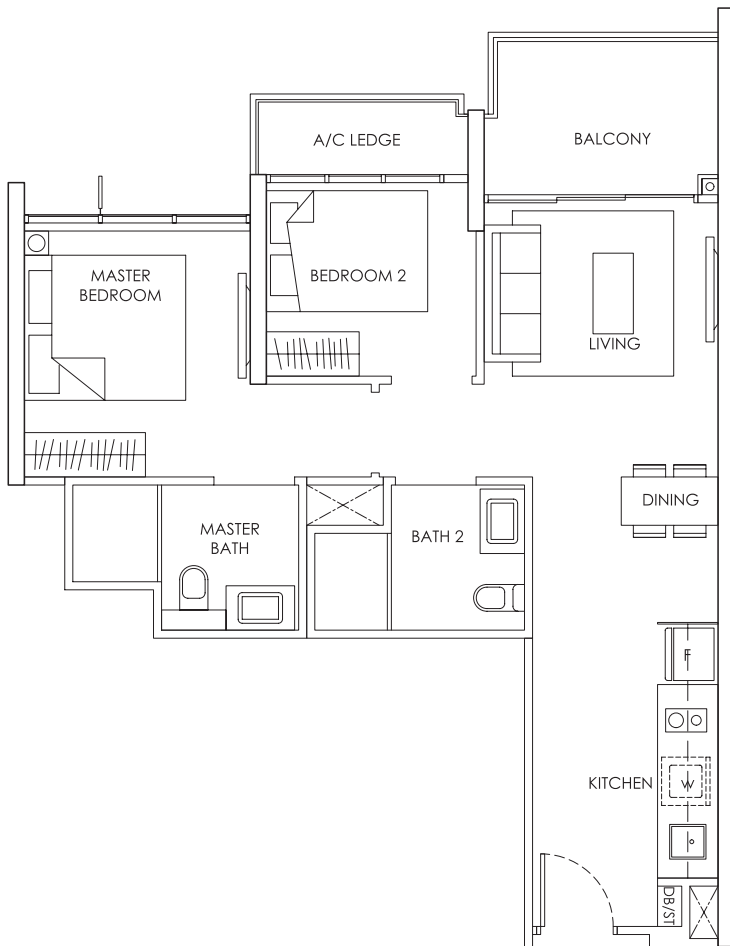

02-03, 07-03, 08-03, 10-03
02-32, 08-32, 10-32

KEY PLAN

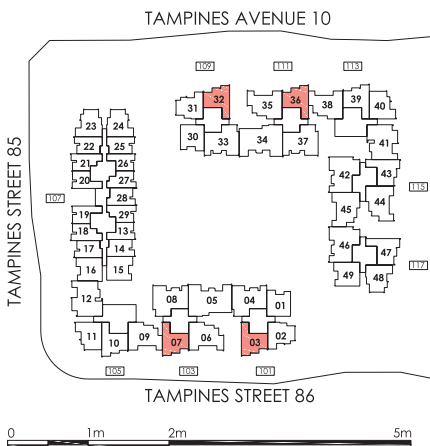

Area includes A/C ledge, balcony, PES, Roof Terrace and Void (where applicable). Orientation and facings will differ depending on the unit you are purchasing (please refer to key plan). All plans are not to scale and subject to changes as may be required by relevant authorities. All appliances and furniture shown in the plan are for illustration purpose only and not representation of fact. All floor areas are estimated and subjected to final survey.

Legend: F - Fridge DB/ST - Distribution Board and Storage space
WC - Water Closet W - Washer cum Dryer A/C - Aircon
PES - Private Enclosed Space

TYPE B1 (CONTINUED)

2 - BEDROOM 64 sqm / 689 sqft

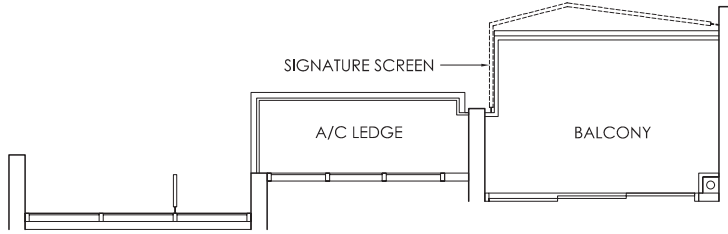

06-07
03-36, 10-36

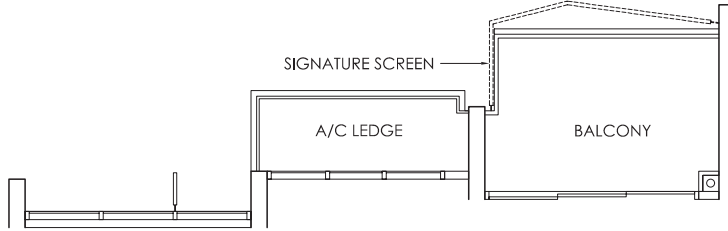

03-03, 05-03
05-32

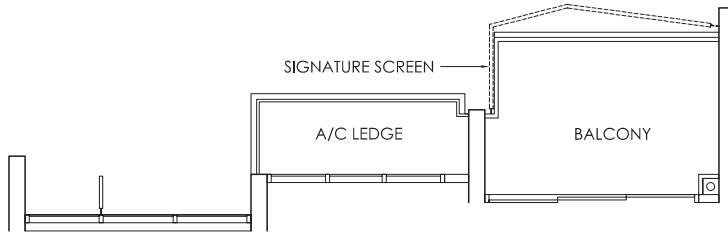

03-07, 12-07
06-36

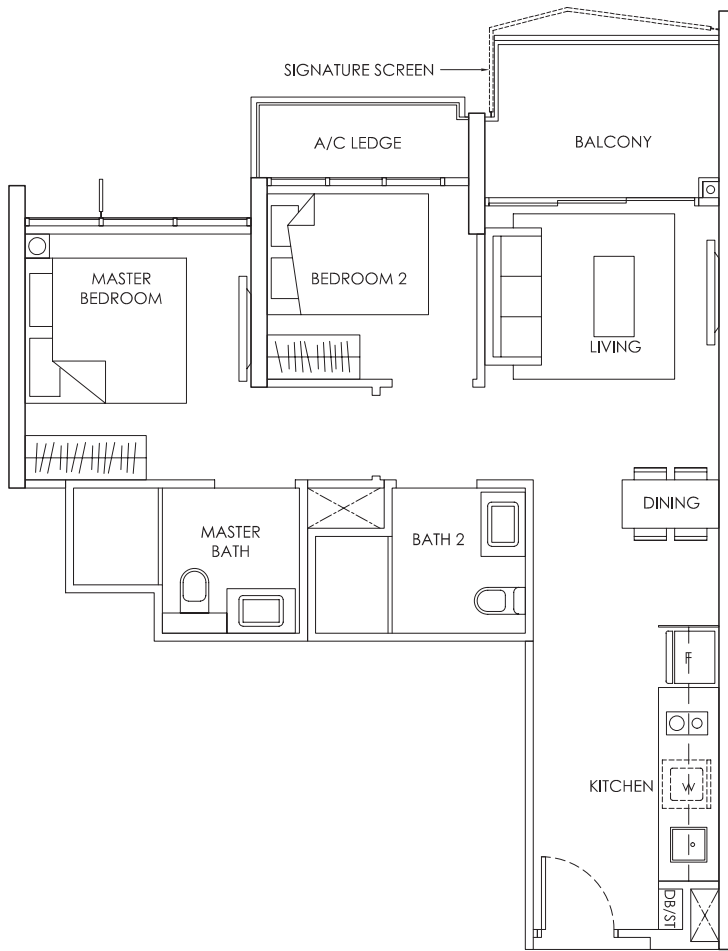

09-03
03-32, 09-32

KEY PLAN

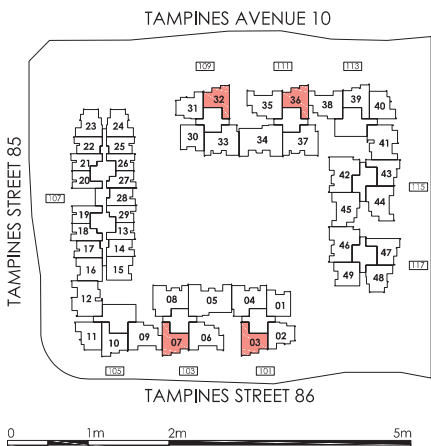

Area includes A/C ledge, balcony, PES, Roof Terrace and Void (where applicable). Orientation and facings will differ depending on the unit you are purchasing (please refer to key plan). All plans are not to scale and subject to changes as may be required by relevant authorities. All appliances and furniture shown in the plan are for illustration purpose only and not representation of fact. All floor areas are estimated and subjected to final survey.

Legend: F - Fridge DB/ST - Distribution Board and Storage space
WC - Water Closet W - Washer cum Dryer A/C - Aircon
PES - Private Enclosed Space

TYPE B1-P

2 - BEDROOM 64 sqm / 689 sqft

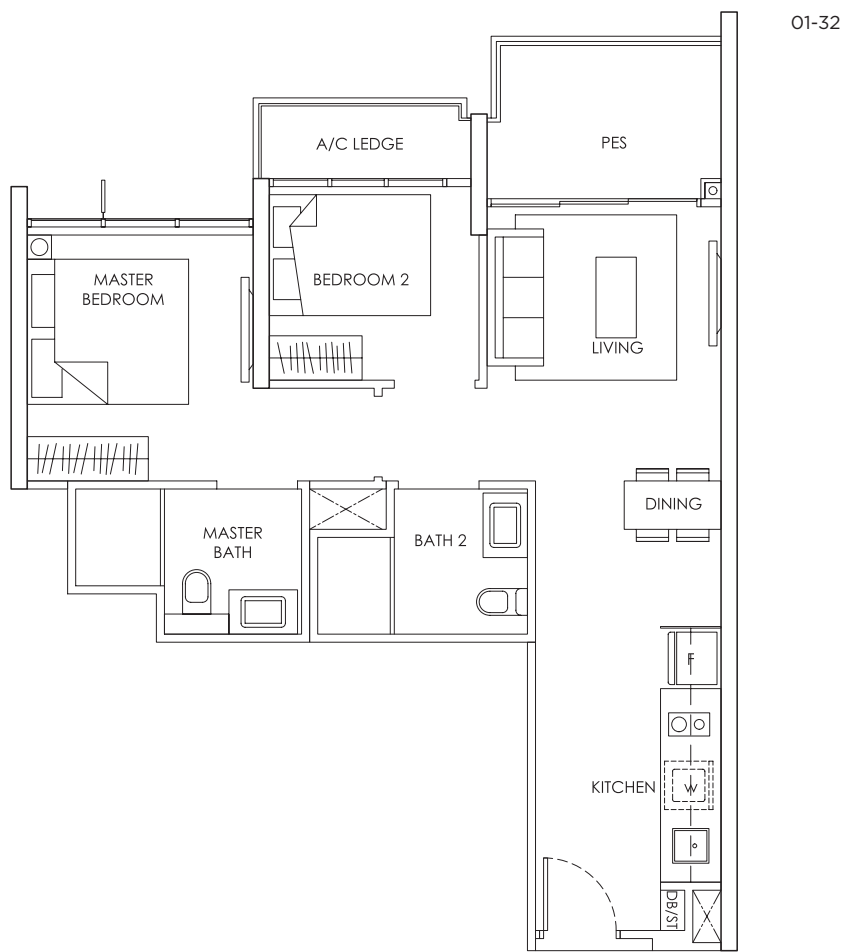
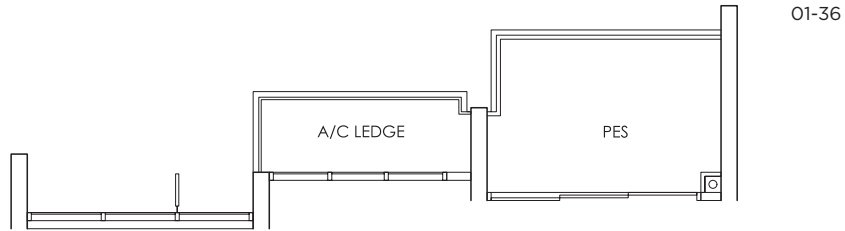

KEY PLAN

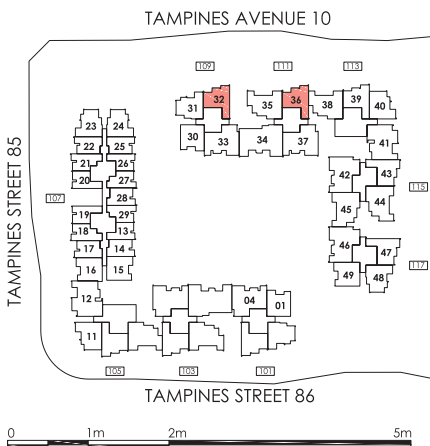

Area includes A/C ledge, balcony, PES, Roof Terrace and Void (where applicable). Orientation and facings will differ depending on the unit you are purchasing (please refer to key plan). All plans are not to scale and subject to changes as may be required by relevant authorities. All appliances and furniture shown in the plan are for illustration purpose only and not representation of fact. All floor areas are estimated and subjected to final survey.

- Legend:
- F - Fridge
 - DB/ST - Distribution Board and Storage space
 - WC - Water Closet
 - W - Washer cum Dryer
 - A/C - Aircon
 - PES - Private Enclosed Space

TYPE B2 (STACK 02 & 31)

2 - BEDROOM 65 sqm / 700 sqft

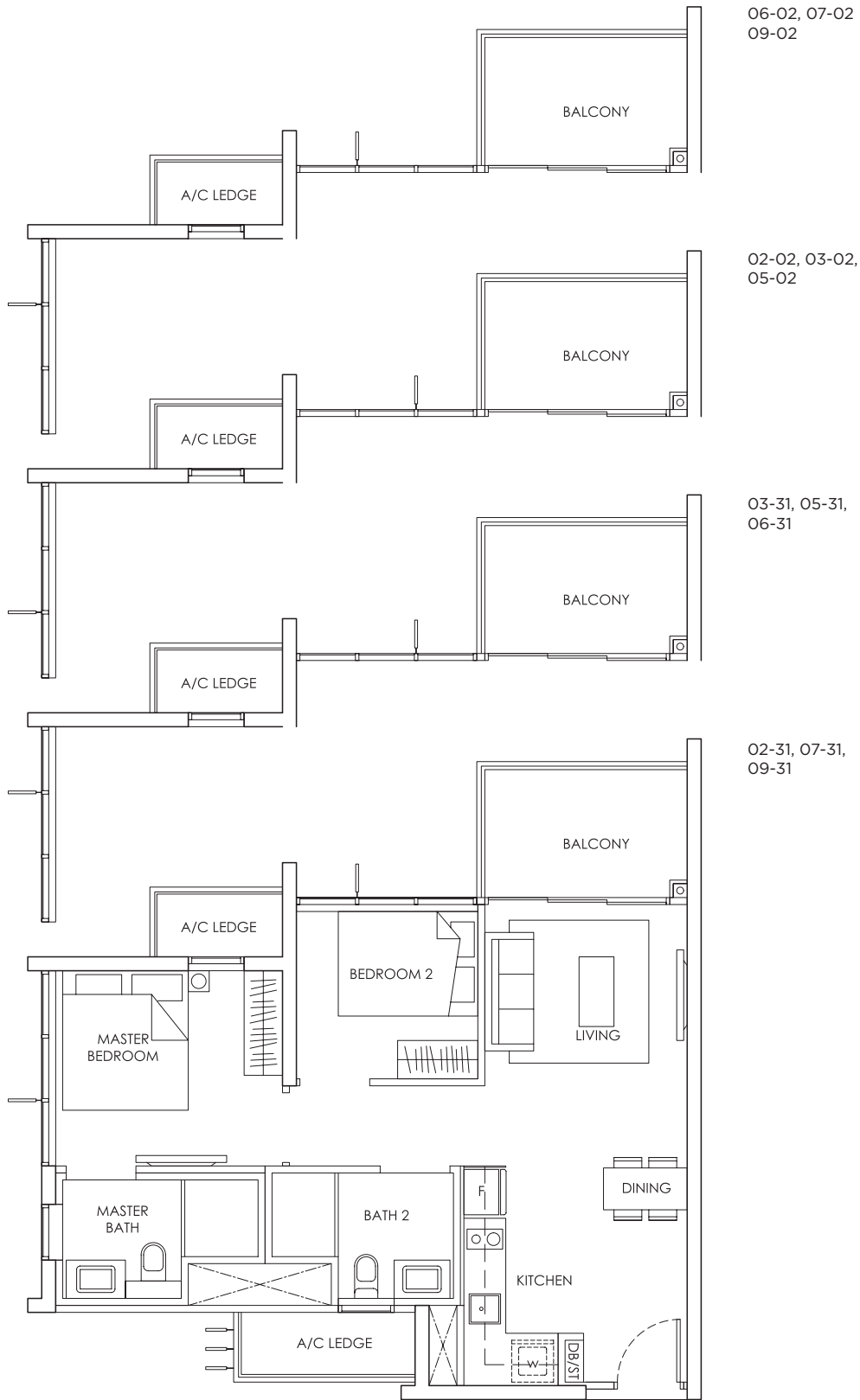

KEY PLAN

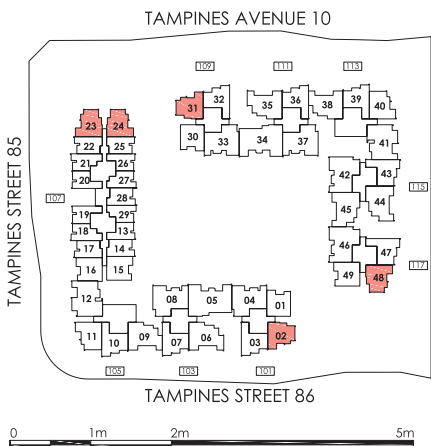

Area includes A/C ledge, balcony, PES, Roof Terrace and Void (where applicable). Orientation and facings will differ depending on the unit you are purchasing (please refer to key plan). All plans are not to scale and subject to changes as may be required by relevant authorities. All appliances and furniture shown in the plan are for illustration purpose only and not representation of fact. All floor areas are estimated and subjected to final survey.

Legend: F - Fridge DB/ST - Distribution Board and Storage space
 WC - Water Closet W - Washer cum Dryer A/C - Aircon
 PES - Private Enclosed Space

TYPE B2 (STACK 02 & 31)

2 - BEDROOM 65 sqm / 700 sqft

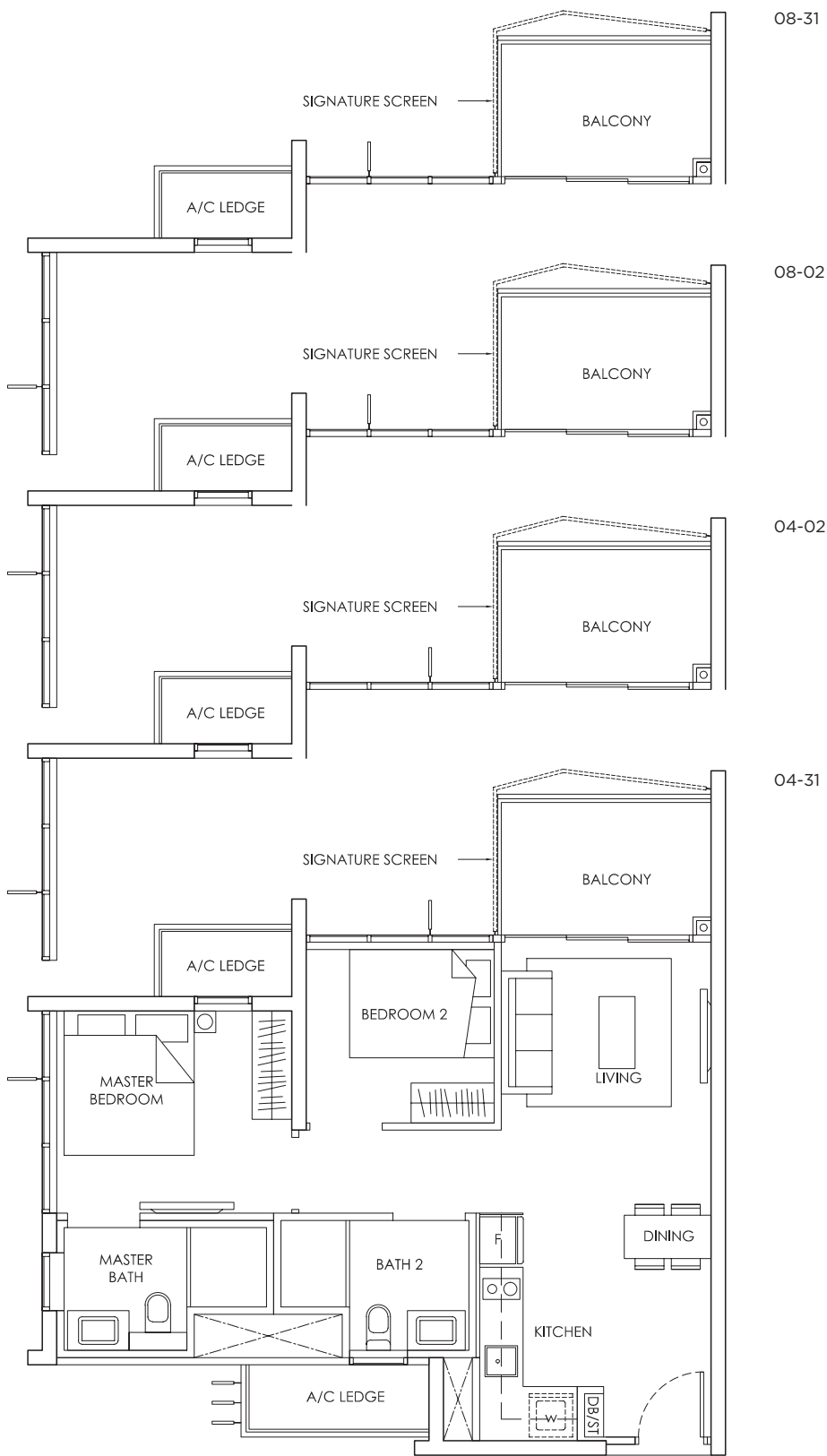

KEY PLAN

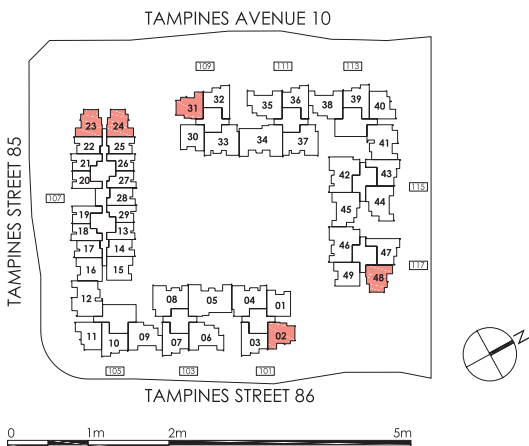

Area includes A/C ledge, balcony, PES, Roof Terrace and Void (where applicable). Orientation and facings will differ depending on the unit you are purchasing (please refer to key plan). All plans are not to scale and subject to changes as may be required by relevant authorities. All appliances and furniture shown in the plan are for illustration purpose only and not representation of fact. All floor areas are estimated and subjected to final survey.

Legend: F - Fridge DB/ST - Distribution Board and Storage space
WC - Water Closet W - Washer cum Dryer A/C - Aircon
PES - Private Enclosed Space

TYPE B2 (STACK 23 & 24)

2 - BEDROOM 65 sqm / 700 sqft

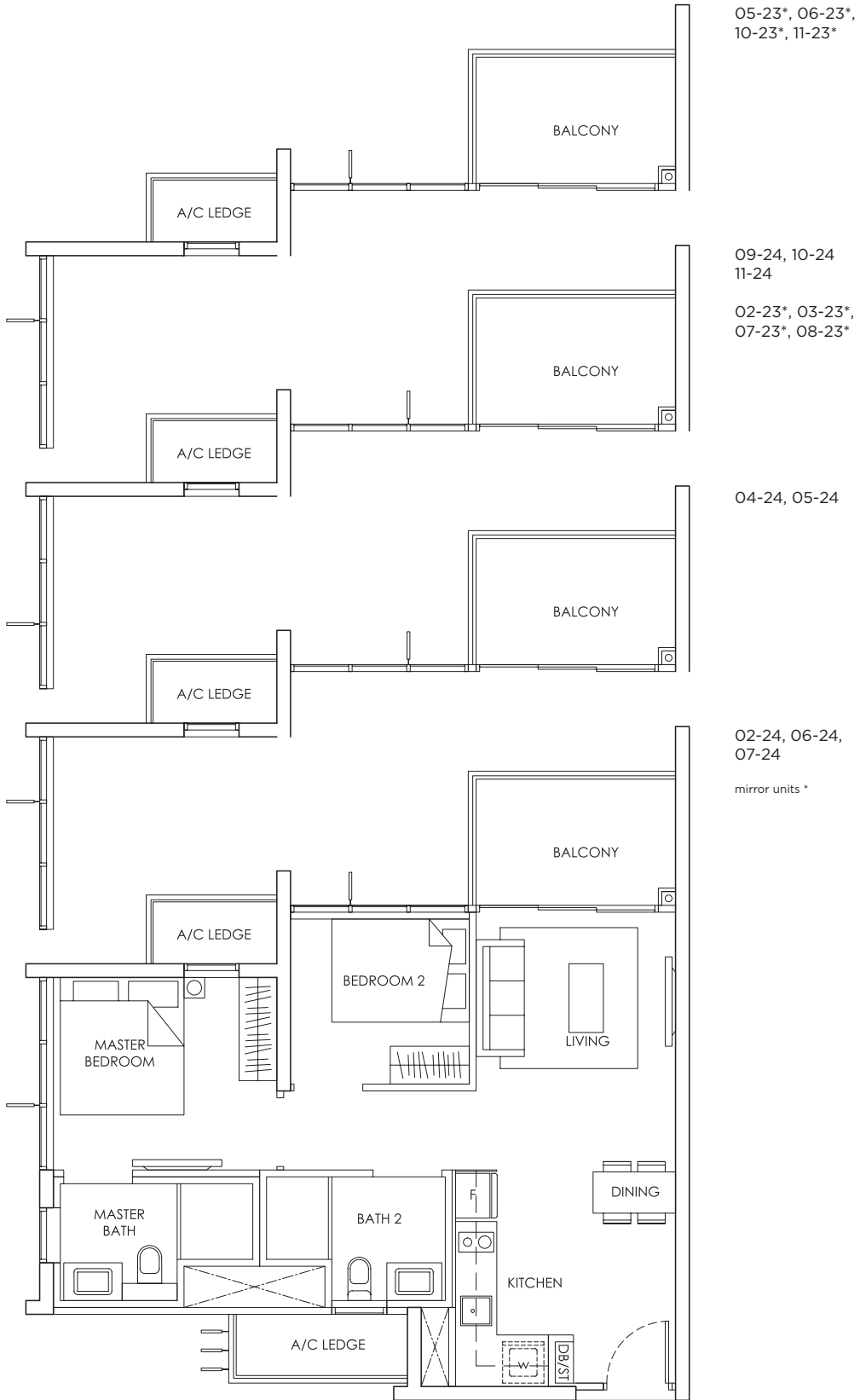

KEY PLAN

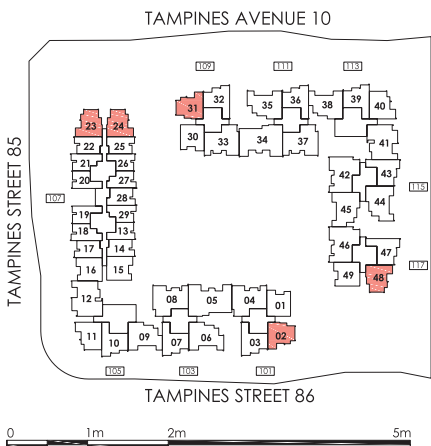

Area includes A/C ledge, balcony, PES, Roof Terrace and Void (where applicable). Orientation and facings will differ depending on the unit you are purchasing (please refer to key plan). All plans are not to scale and subject to changes as may be required by relevant authorities. All appliances and furniture shown in the plan are for illustration purpose only and not representation of fact. All floor areas are estimated and subjected to final survey.

- Legend:
- F - Fridge
 - DB/ST - Distribution Board and Storage space
 - WC - Water Closet
 - W - Washer cum Dryer
 - A/C - Aircon
 - PES - Private Enclosed Space

TYPE B2 (STACK 23 & 24)

2 - BEDROOM 65 sqm / 700 sqft

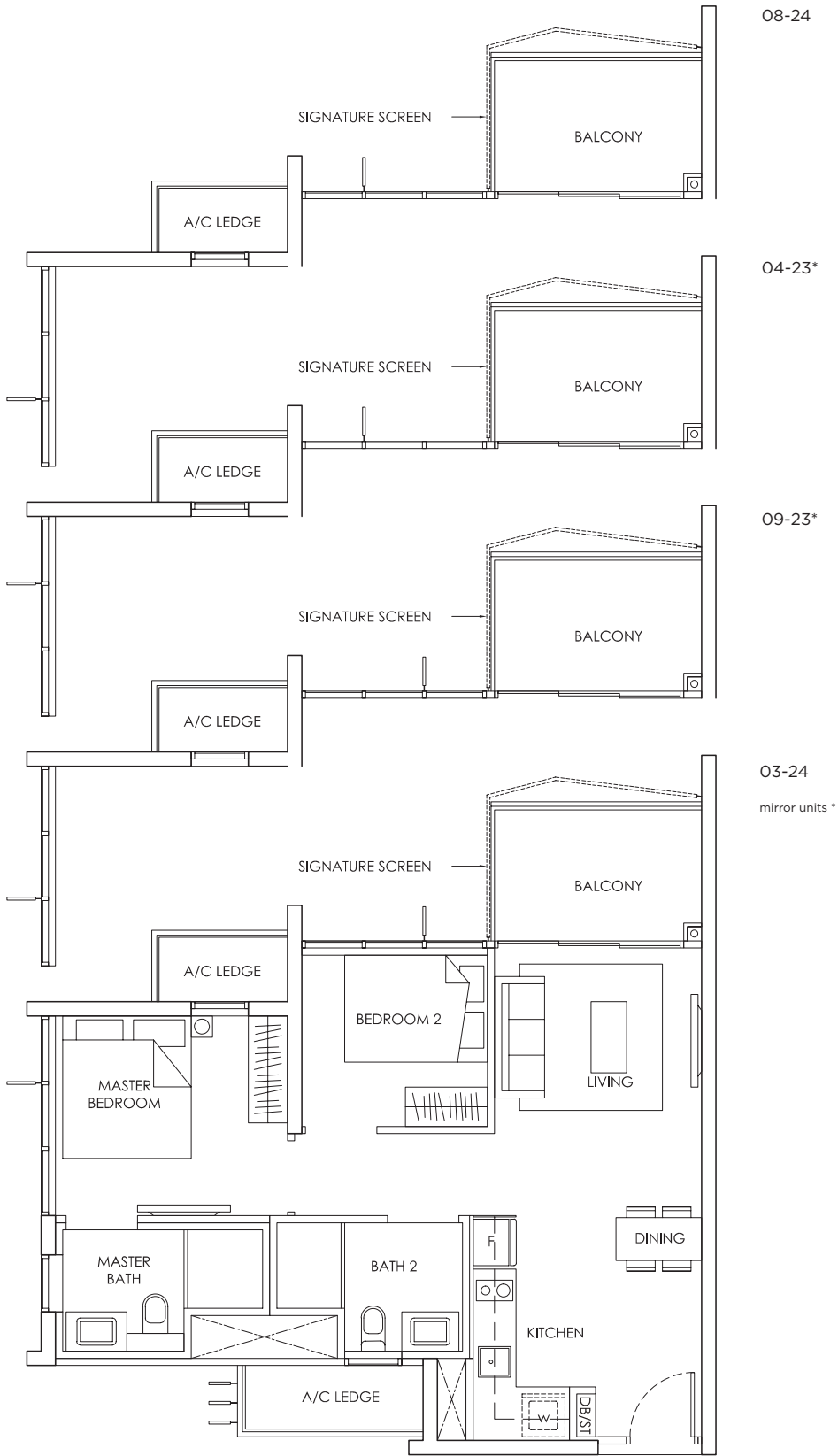

KEY PLAN

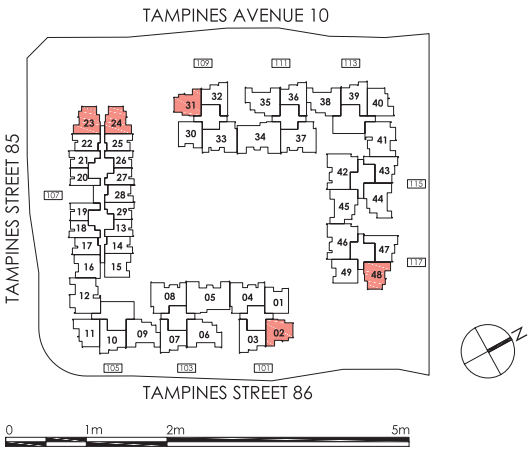

Area includes A/C ledge, balcony, PES, Roof Terrace and Void (where applicable). Orientation and facings will differ depending on the unit you are purchasing (please refer to key plan). All plans are not to scale and subject to changes as may be required by relevant authorities. All appliances and furniture shown in the plan are for illustration purpose only and not representation of fact. All floor areas are estimated and subjected to final survey.

- Legend:
- F - Fridge
 - DB/ST - Distribution Board and Storage space
 - WC - Water Closet
 - W - Washer cum Dryer
 - A/C - Aircon
 - PES - Private Enclosed Space

TYPE B2 (STACK 48)

2 - BEDROOM 65 sqm / 700 sqft

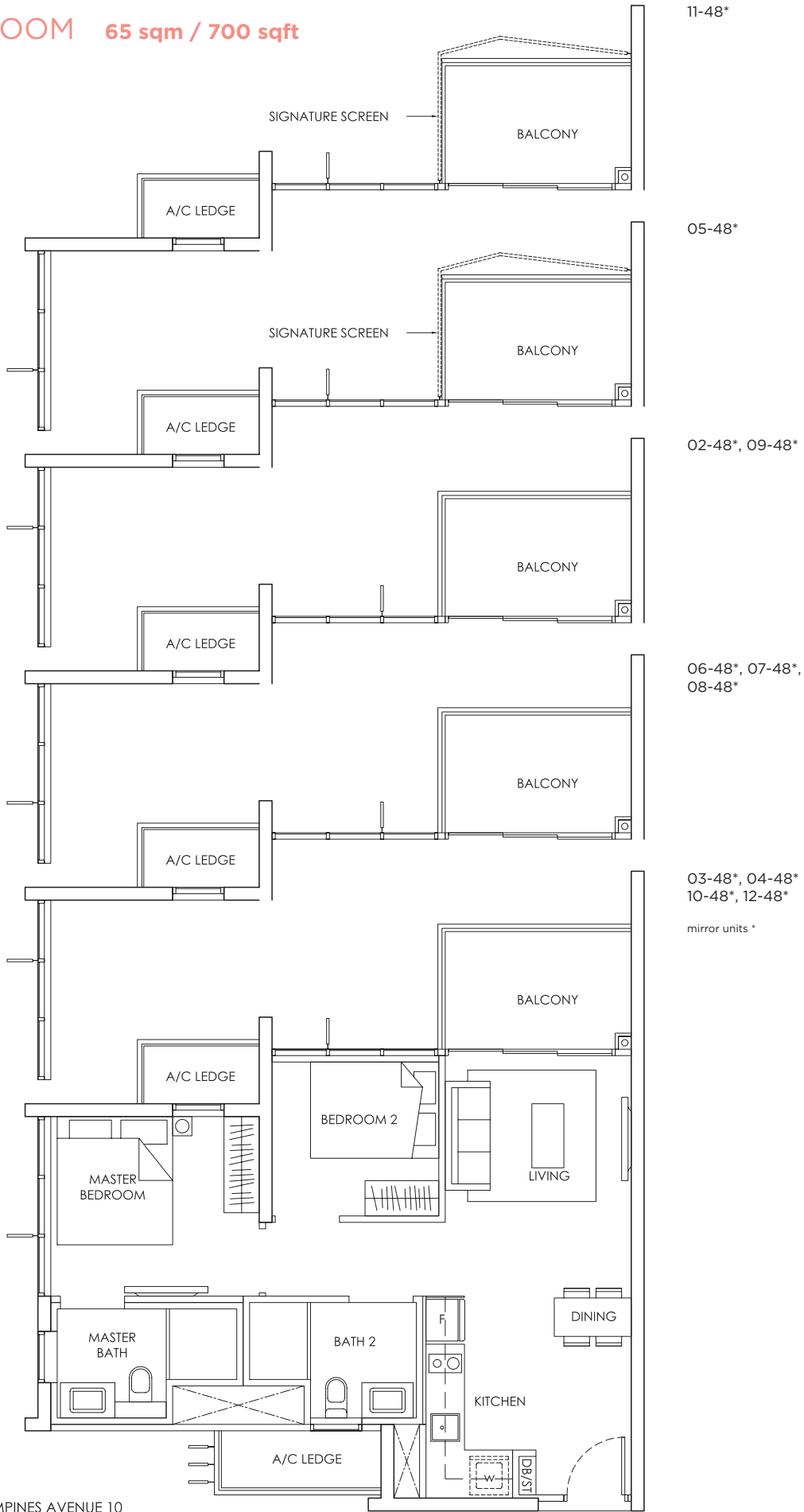

KEY PLAN

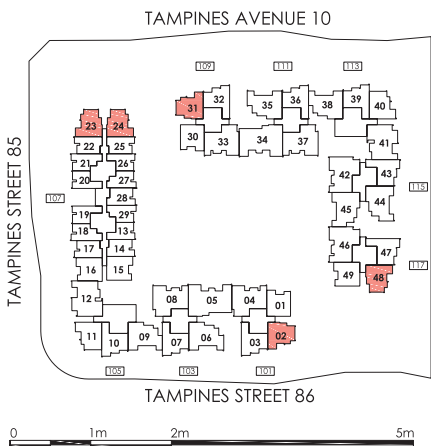

Area includes A/C ledge, balcony, PES, Roof Terrace and Void (where applicable). Orientation and facings will differ depending on the unit you are purchasing (please refer to key plan). All plans are not to scale and subject to changes as may be required by relevant authorities. All appliances and furniture shown in the plan are for illustration purpose only and not representation of fact. All floor areas are estimated and subjected to final survey.

Legend: F - Fridge DB/ST - Distribution Board and Storage space
 WC - Water Closet W - Washer cum Dryer A/C - Aircon
 PES - Private Enclosed Space

TYPE B2-P

2 - BEDROOM 65 sqm / 700 sqft

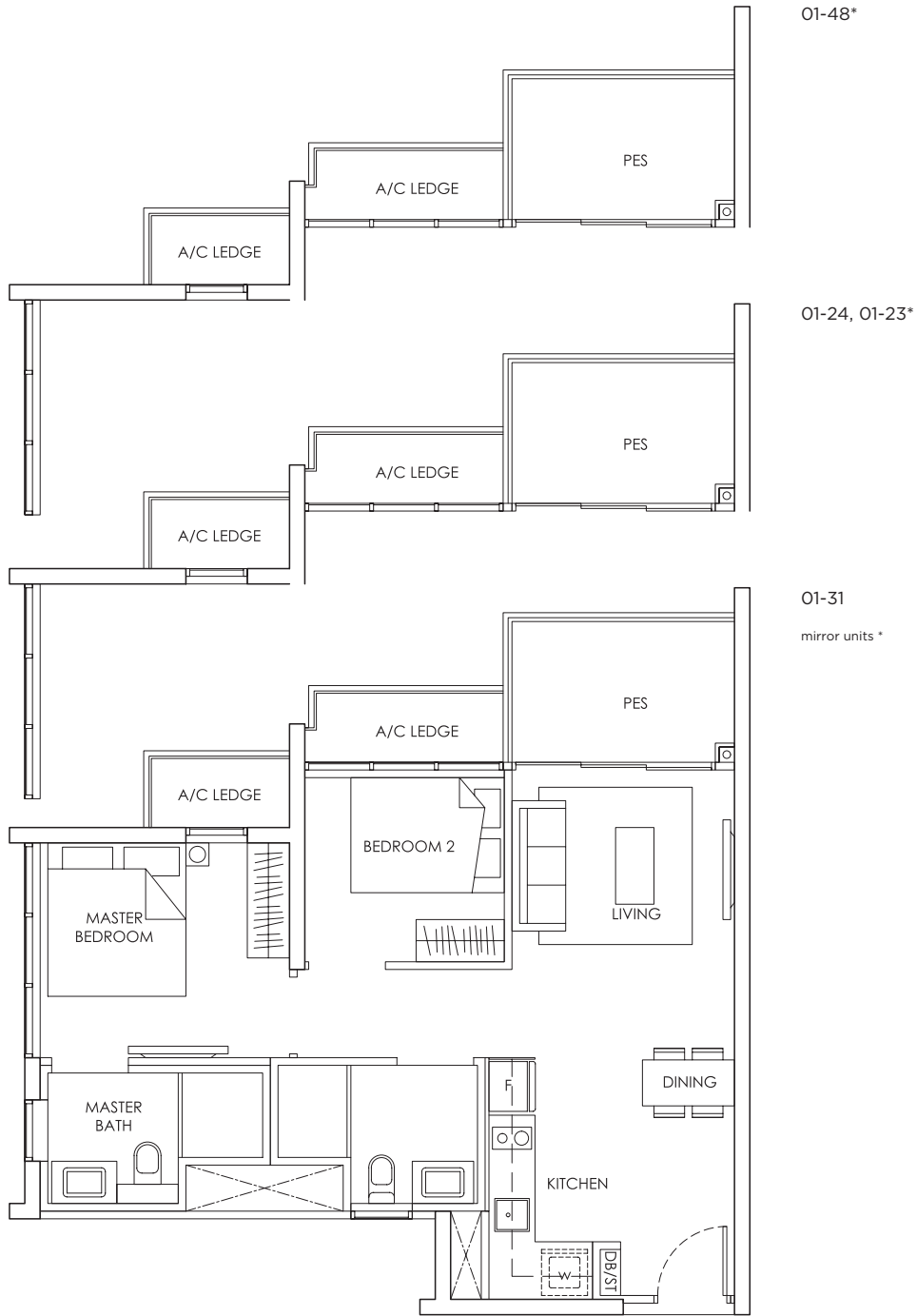

KEY PLAN

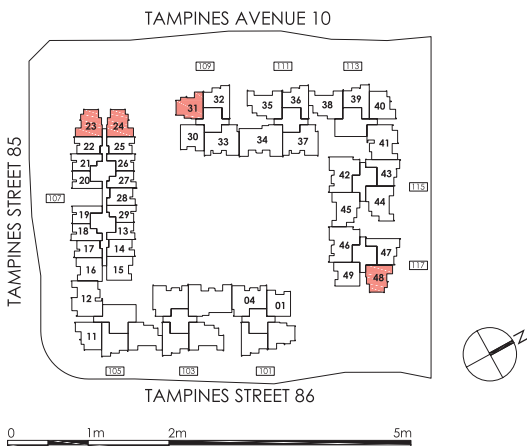

Area includes A/C ledge, balcony, PES, Roof Terrace and Void (where applicable). Orientation and facings will differ depending on the unit you are purchasing (please refer to key plan). All plans are not to scale and subject to changes as may be required by relevant authorities. All appliances and furniture shown in the plan are for illustration purpose only and not representation of fact. All floor areas are estimated and subjected to final survey.

- Legend:
- F - Fridge
 - DB/ST - Distribution Board and Storage space
 - WC - Water Closet
 - W - Washer cum Dryer
 - A/C - Aircon
 - PES - Private Enclosed Space

TYPE B3 (STACK 01, 30 & 49)

2 - BEDROOM 65 sqm / 700 sqft

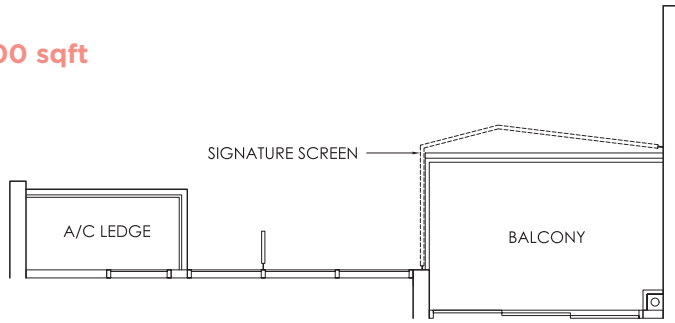

03-49
06-01*, 08-01*
06-30*

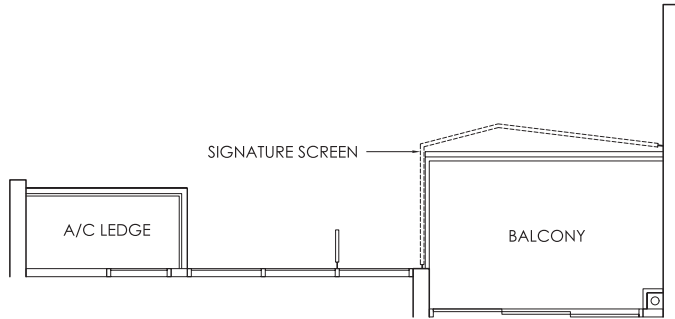

08-49
03-01*
03-30, 08-30*

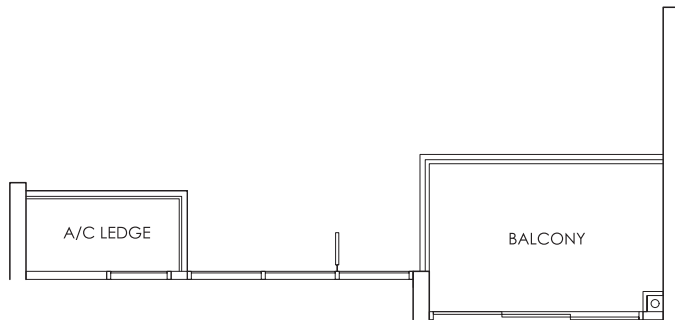

05-49, 06-49,
07-49
04-01*, 05-01*,
09-01*
02-30*, 04-30*,
09-30*

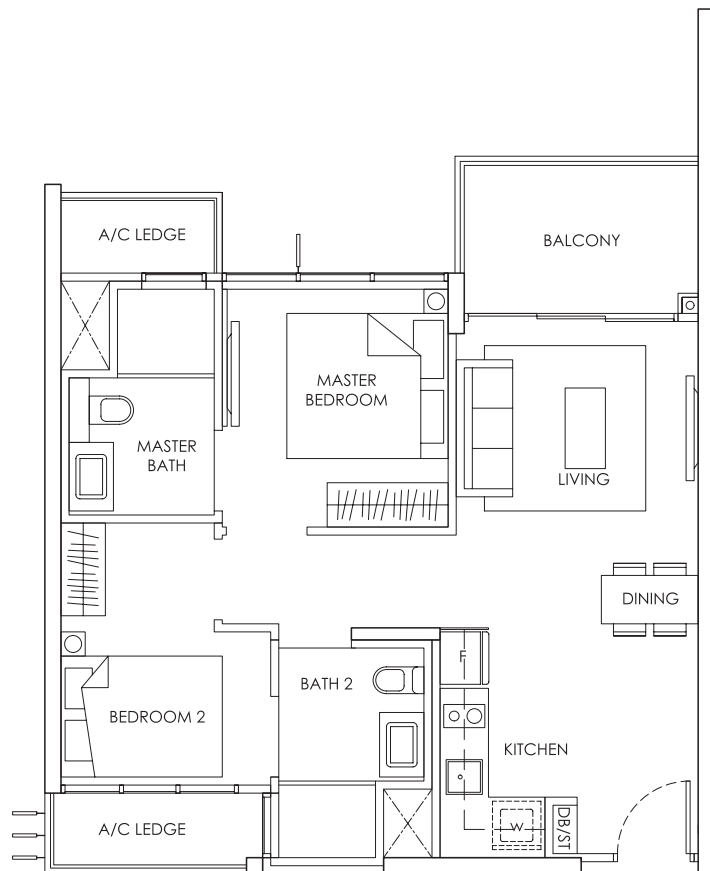

02-49, 04-49
09-49 to 12-49
02-01*, 07-01*
05-30*, 07-30*
mirror units *

KEY PLAN

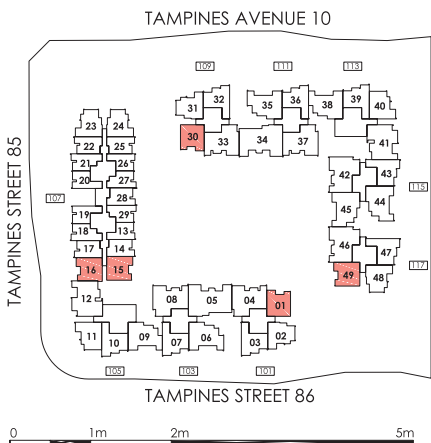

Area includes A/C ledge, balcony, PES, Roof Terrace and Void (where applicable). Orientation and facings will differ depending on the unit you are purchasing (please refer to key plan). All plans are not to scale and subject to changes as may be required by relevant authorities. All appliances and furniture shown in the plan are for illustration purpose only and not representation of fact. All floor areas are estimated and subjected to final survey.

Legend: F - Fridge DB/ST - Distribution Board and Storage space
WC - Water Closet W - Washer cum Dryer A/C - Aircon
PES - Private Enclosed Space

TYPE B3 (STACK 15)

2 - BEDROOM 65 sqm / 700 sqft

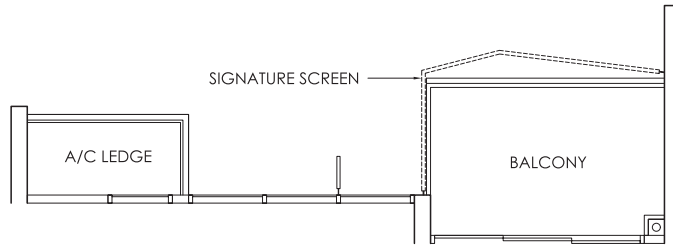

03-15*, 09-15*, 14-15*

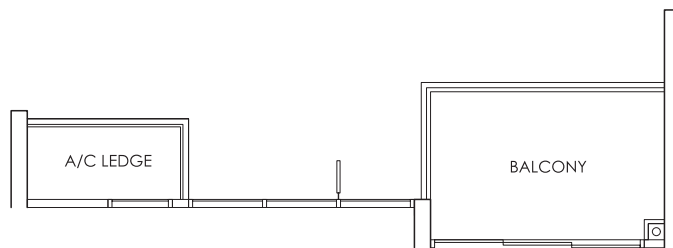

02-15*, 07-15*, 08-15*

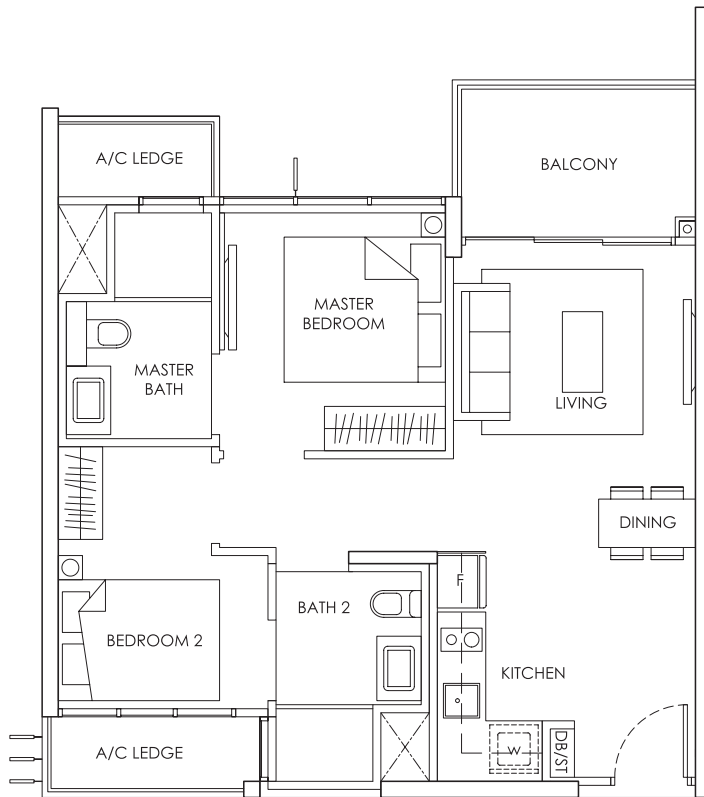

04-15* to 06-15*
10-15* to 13-15*

mirror units *

KEY PLAN

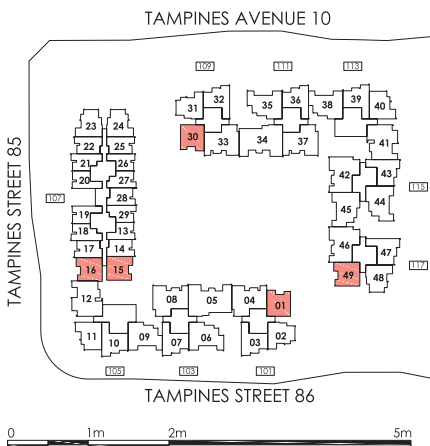

Area includes A/C ledge, balcony, PES, Roof Terrace and Void (where applicable). Orientation and facings will differ depending on the unit you are purchasing (please refer to key plan). All plans are not to scale and subject to changes as may be required by relevant authorities. All appliances and furniture shown in the plan are for illustration purpose only and not representation of fact. All floor areas are estimated and subjected to final survey.

Legend: F - Fridge DB/ST - Distribution Board and Storage space
WC - Water Closet W - Washer cum Dryer A/C - Aircon
PES - Private Enclosed Space

TYPE B3 (STACK 16)

2 - BEDROOM 65 sqm / 700 sqft

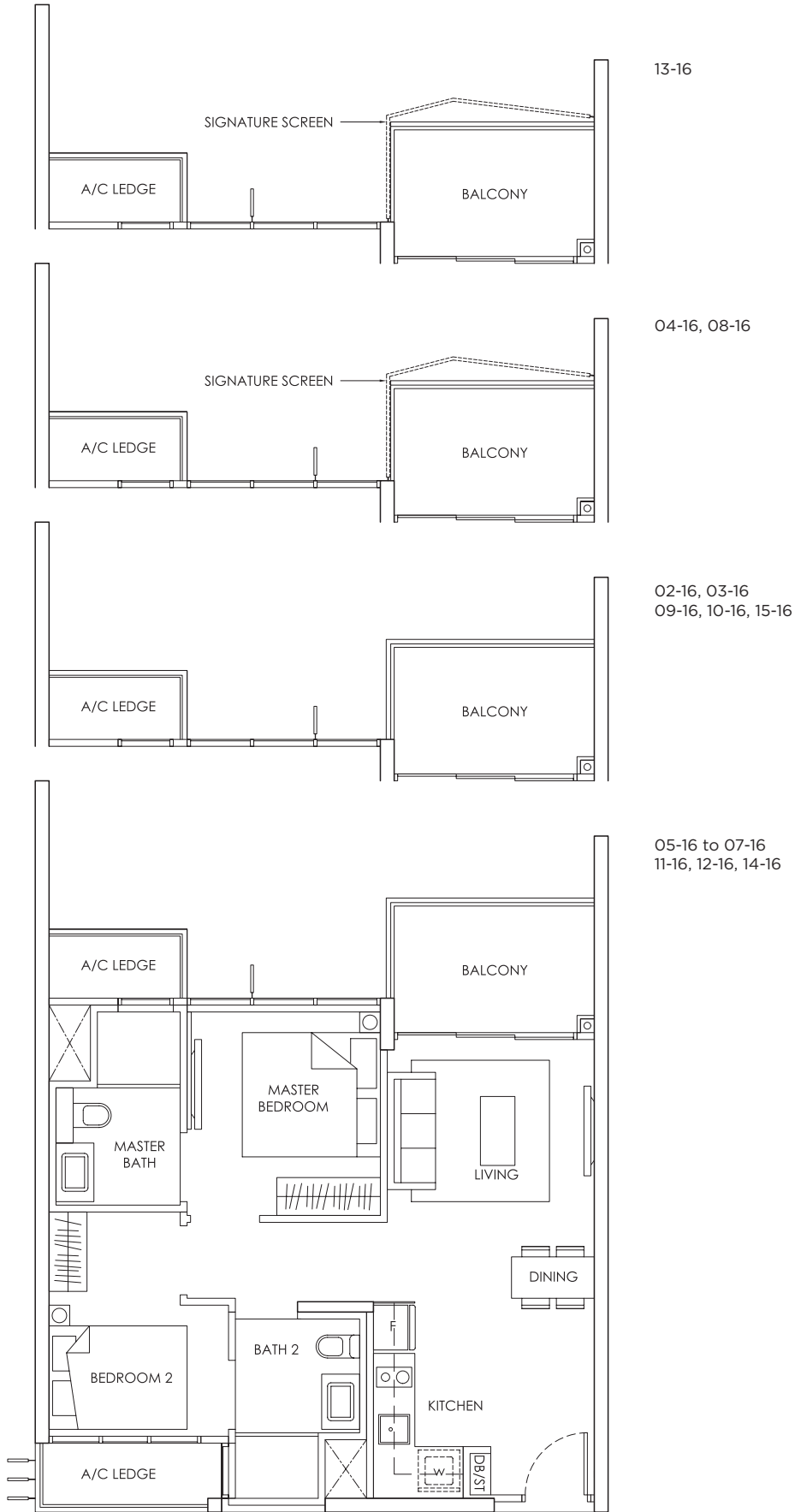

KEY PLAN

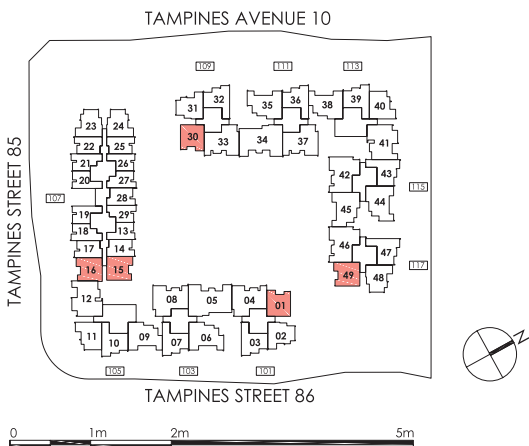

Area includes A/C ledge, balcony, PES, Roof Terrace and Void (where applicable). Orientation and facings will differ depending on the unit you are purchasing (please refer to key plan). All plans are not to scale and subject to changes as may be required by relevant authorities. All appliances and furniture shown in the plan are for illustration purpose only and not representation of fact. All floor areas are estimated and subjected to final survey.

Legend: F - Fridge DB/ST - Distribution Board and Storage space
 WC - Water Closet W - Washer cum Dryer A/C - Aircon
 PES - Private Enclosed Space

TYPE B3-P

2 - BEDROOM 65 sqm / 700 sqft

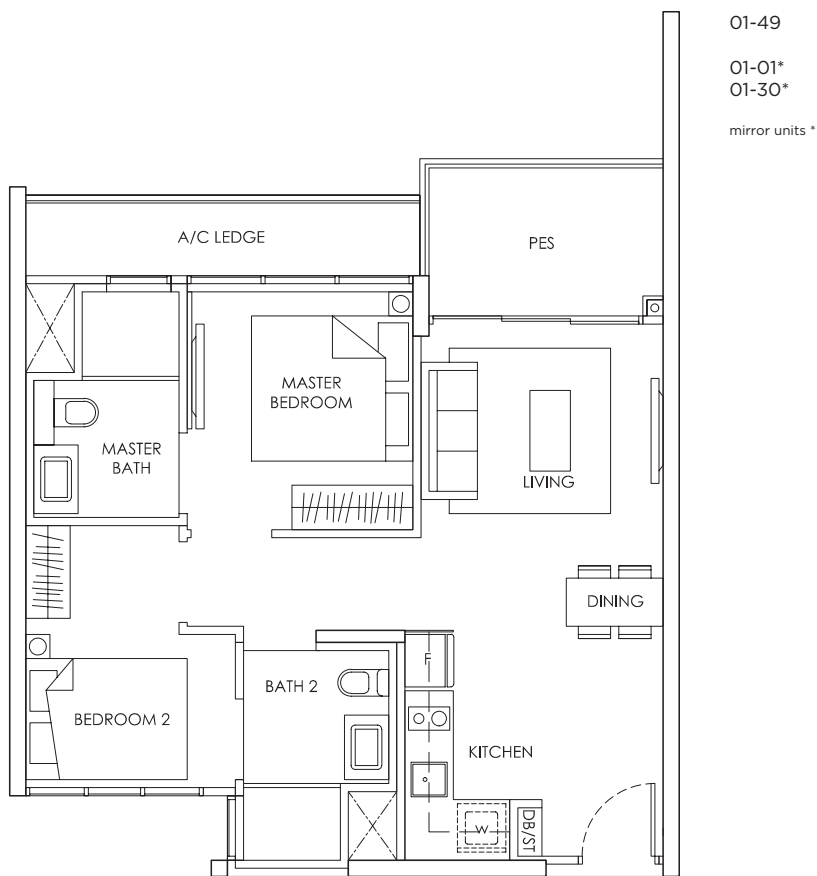
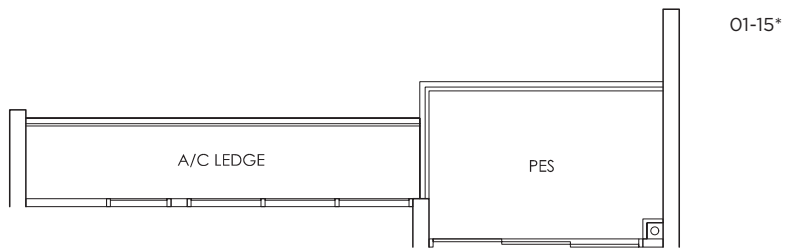
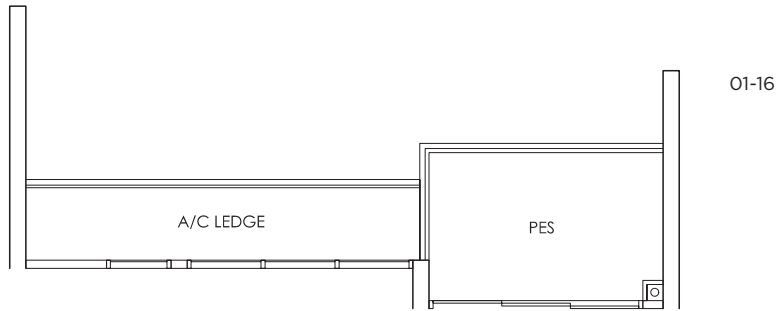

KEY PLAN

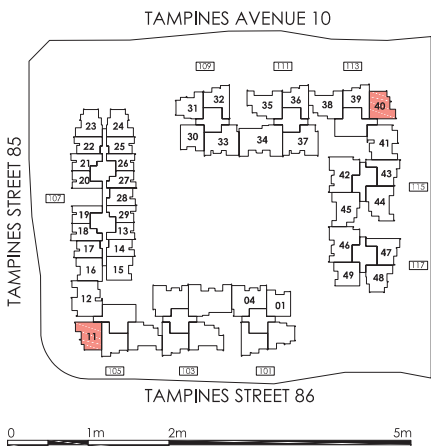

Area includes A/C ledge, balcony, PES, Roof Terrace and Void (where applicable). Orientation and facings will differ depending on the unit you are purchasing (please refer to key plan). All plans are not to scale and subject to changes as may be required by relevant authorities. All appliances and furniture shown in the plan are for illustration purpose only and not representation of fact. All floor areas are estimated and subjected to final survey.

Legend: F - Fridge DB/ST - Distribution Board and Storage space
WC - Water Closet W - Washer cum Dryer A/C - Aircon
PES - Private Enclosed Space

TYPE B4

2 - BEDROOM 65 sqm / 700 sqft

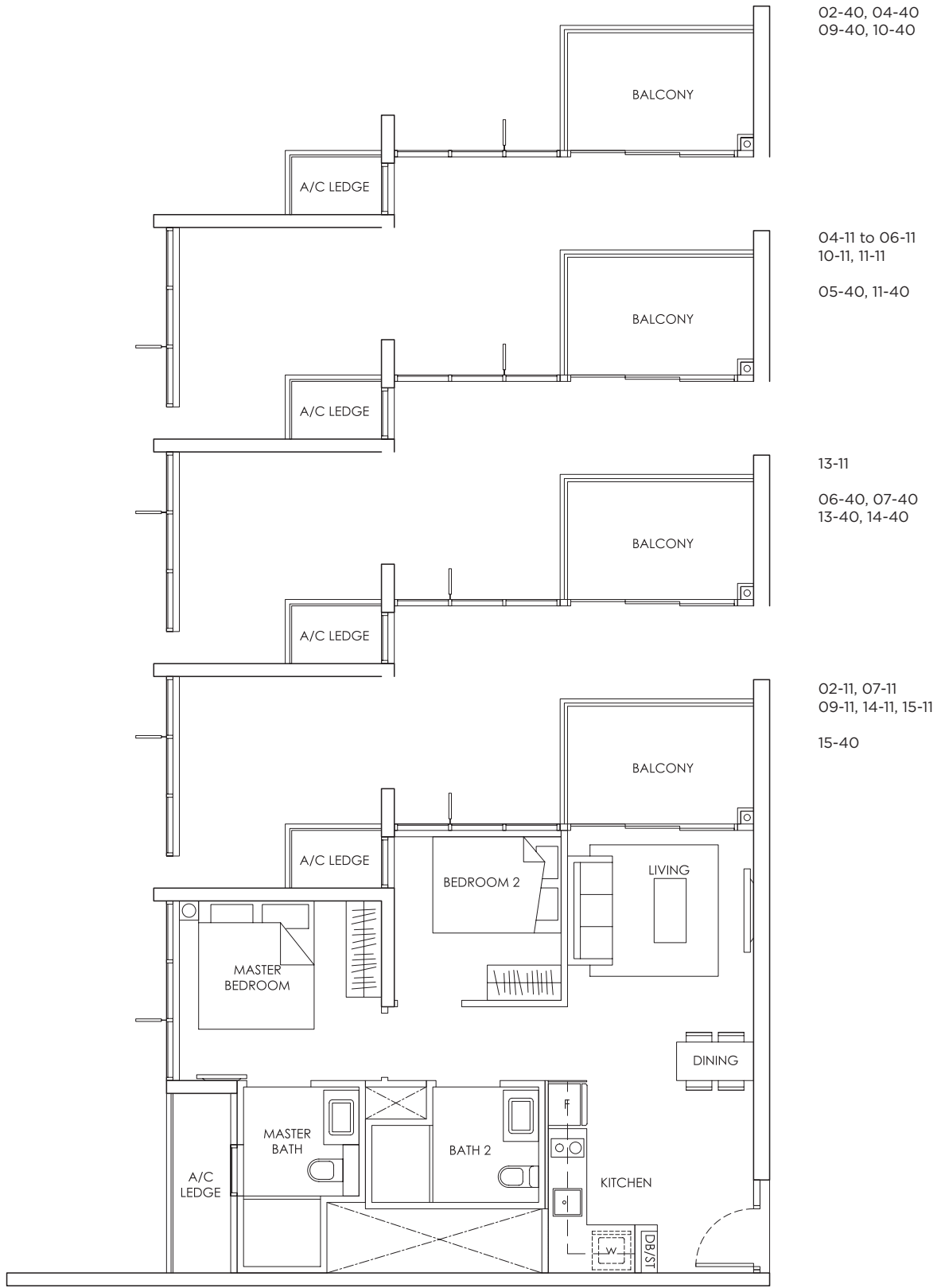

KEY PLAN

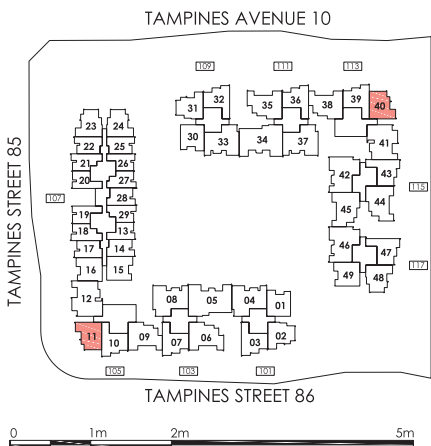

Area includes A/C ledge, balcony, PES, Roof Terrace and Void (where applicable). Orientation and facings will differ depending on the unit you are purchasing (please refer to key plan). All plans are not to scale and subject to changes as may be required by relevant authorities. All appliances and furniture shown in the plan are for illustration purpose only and not representation of fact. All floor areas are estimated and subjected to final survey.

Legend: F - Fridge DB/ST - Distribution Board and Storage space
WC - Water Closet W - Washer cum Dryer A/C - Aircon
PES - Private Enclosed Space

TYPE B4 (CONTINUED)

2 - BEDROOM 65 sqm / 700 sqft

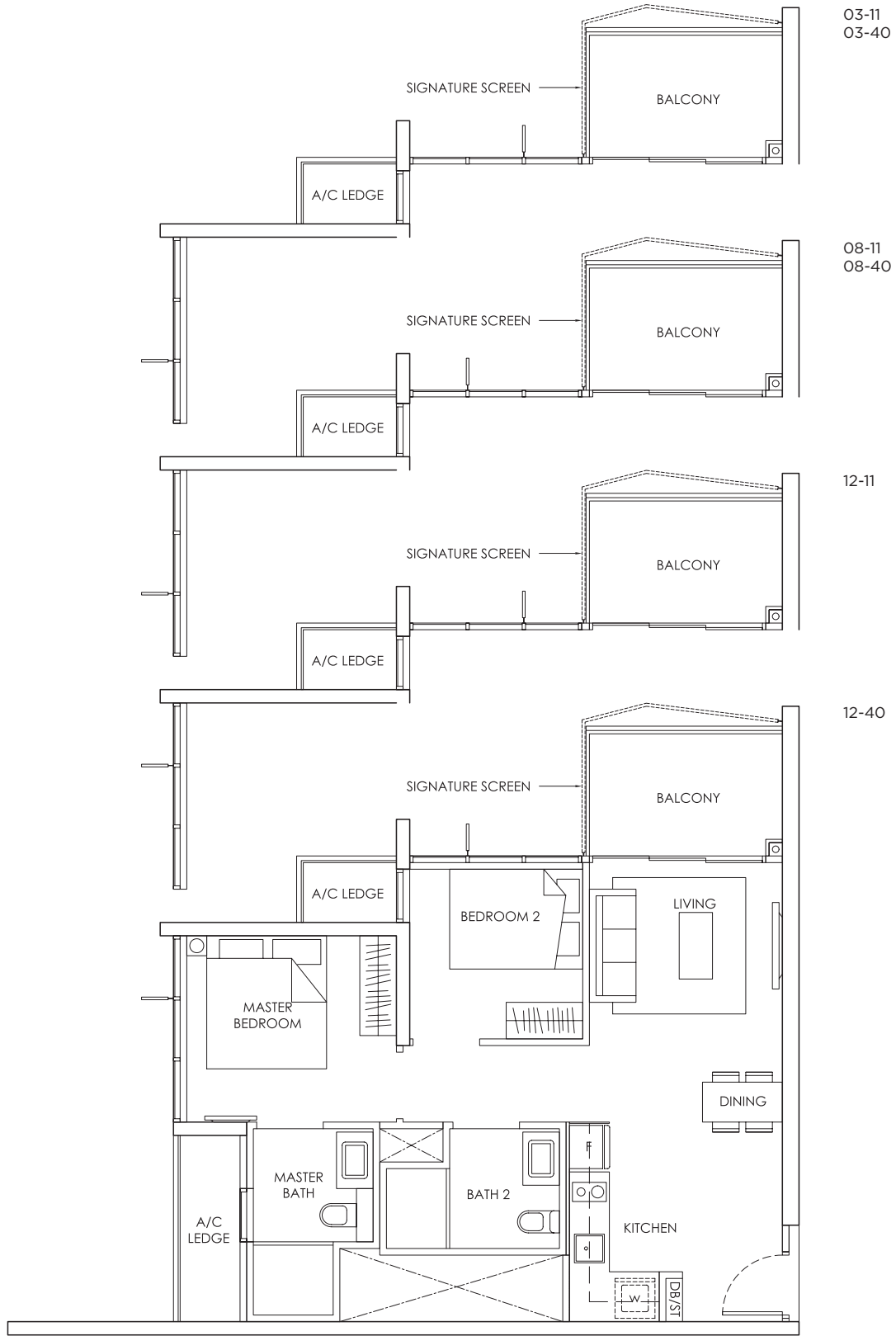

KEY PLAN

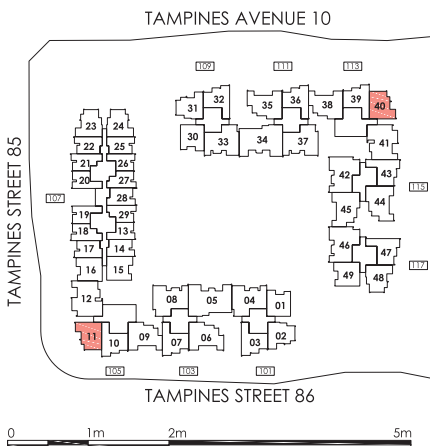

Area includes A/C ledge, balcony, PES, Roof Terrace and Void (where applicable). Orientation and facings will differ depending on the unit you are purchasing (please refer to key plan). All plans are not to scale and subject to changes as may be required by relevant authorities. All appliances and furniture shown in the plan are for illustration purpose only and not representation of fact. All floor areas are estimated and subjected to final survey.

- Legend: F - Fridge DB/ST - Distribution Board and Storage space
WC - Water Closet W - Washer cum Dryer A/C - Aircon
PES - Private Enclosed Space

TYPE B4-P

2 - BEDROOM 65 sqm / 700 sqft

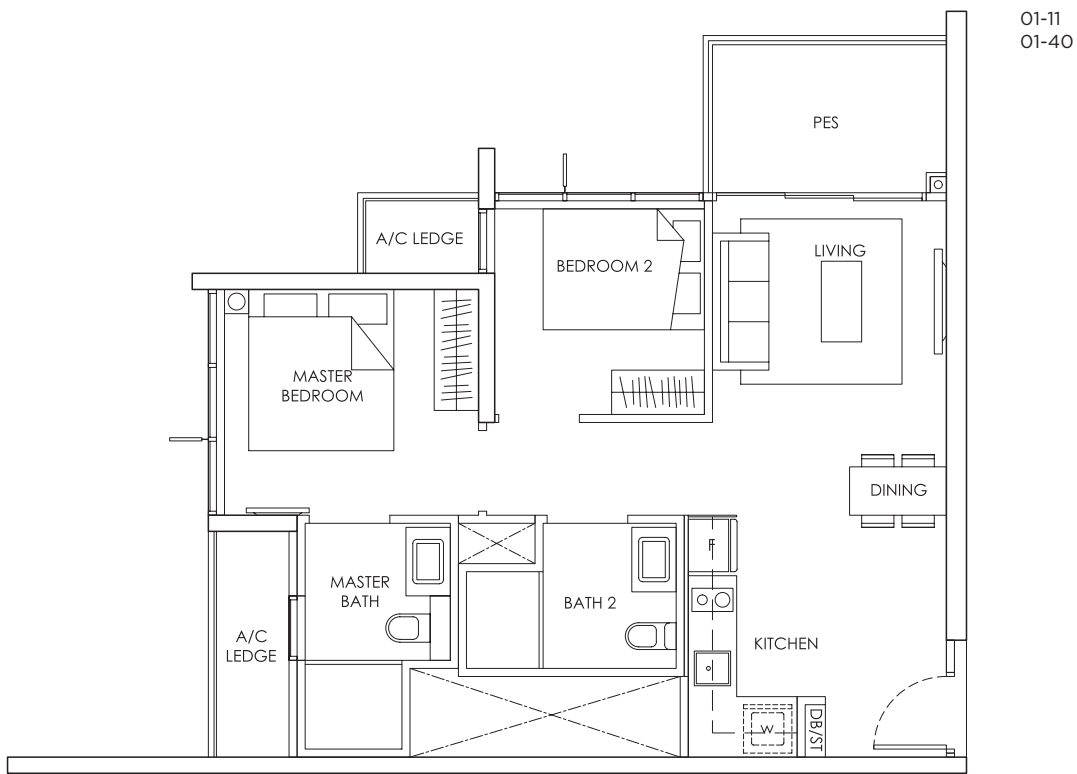

2 - BEDROOM

KEY PLAN

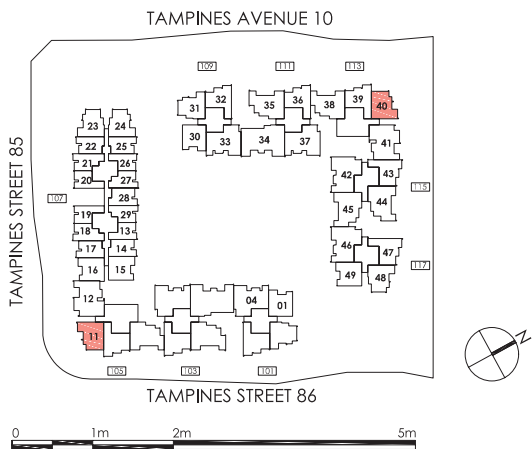

Area includes A/C ledge, balcony, PES, Roof Terrace and Void (where applicable). Orientation and facings will differ depending on the unit you are purchasing (please refer to key plan). All plans are not to scale and subject to changes as may be required by relevant authorities. All appliances and furniture shown in the plan are for illustration purpose only and not representation of fact. All floor areas are estimated and subjected to final survey.

- Legend:
- F - Fridge DB/ST - Distribution Board and Storage space
 - WC - Water Closet W - Washer cum Dryer A/C - Aircon
 - PES - Private Enclosed Space

TYPE BSI

2 - BEDROOM + STUDY 64 sqm / 689 sqft

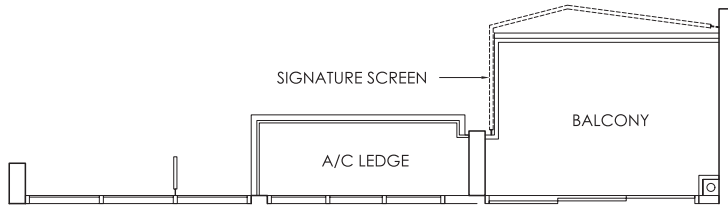

12-43*
03-47*, 08-47*

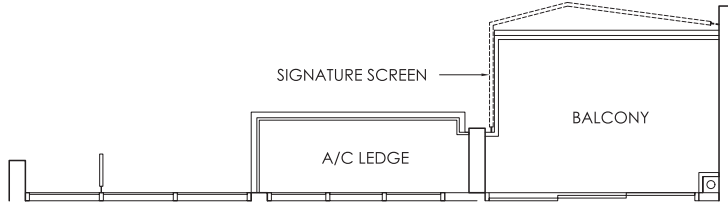

03-43*, 08-43*
12-47*

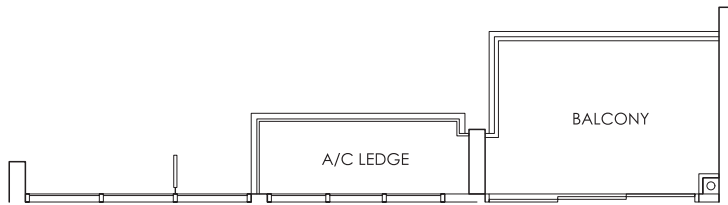

03-10 to 05-10, 09-10 to 12-10
04-39 to 06-39, 10-39 to 13-39

04-43* to 06-43*
10-43*, 11-43*, 13-43*

02-47*, 07-47*, 09-47*, 10-47*

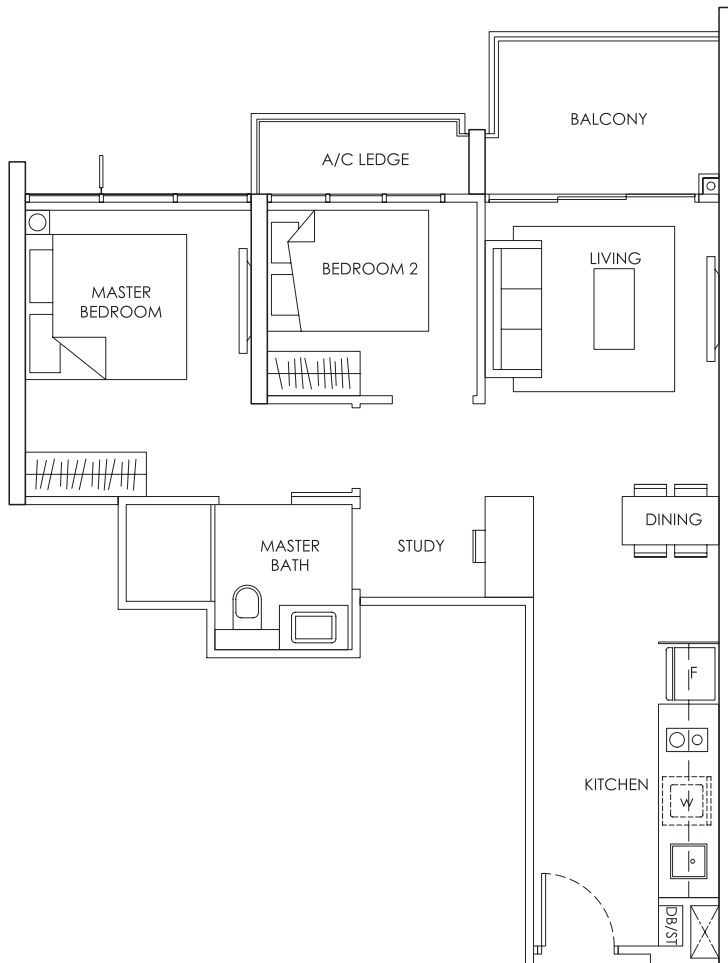

02-10, 06-10 to 08-10
13-10, 14-10

02-39, 03-39
07-39 to 09-39, 14-39

02-43*, 07-43*
09-43*, 14-43*, 15-43*

04-47* to 06-47*
11-47*, 13-47*

mirror units *

KEY PLAN

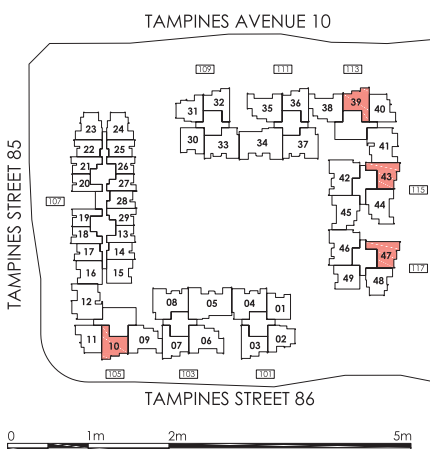

Area includes A/C ledge, balcony, PES, Roof Terrace and Void (where applicable). Orientation and facings will differ depending on the unit you are purchasing (please refer to key plan). All plans are not to scale and subject to changes as may be required by relevant authorities. All appliances and furniture shown in the plan are for illustration purpose only and not representation of fact. All floor areas are estimated and subjected to final survey.

Legend: F - Fridge DB/ST - Distribution Board and Storage space
WC - Water Closet W - Washer cum Dryer A/C - Aircon
PES - Private Enclosed Space

TYPE BSI-P

2 - BEDROOM + STUDY 64 sqm / 689 sqft

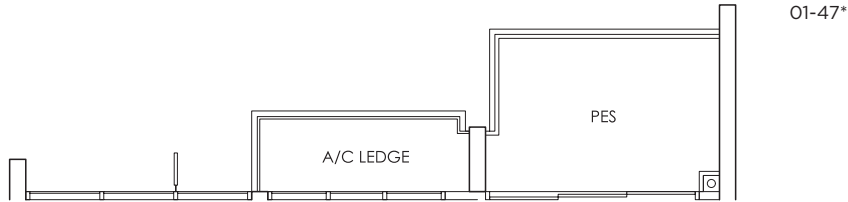

01-47*

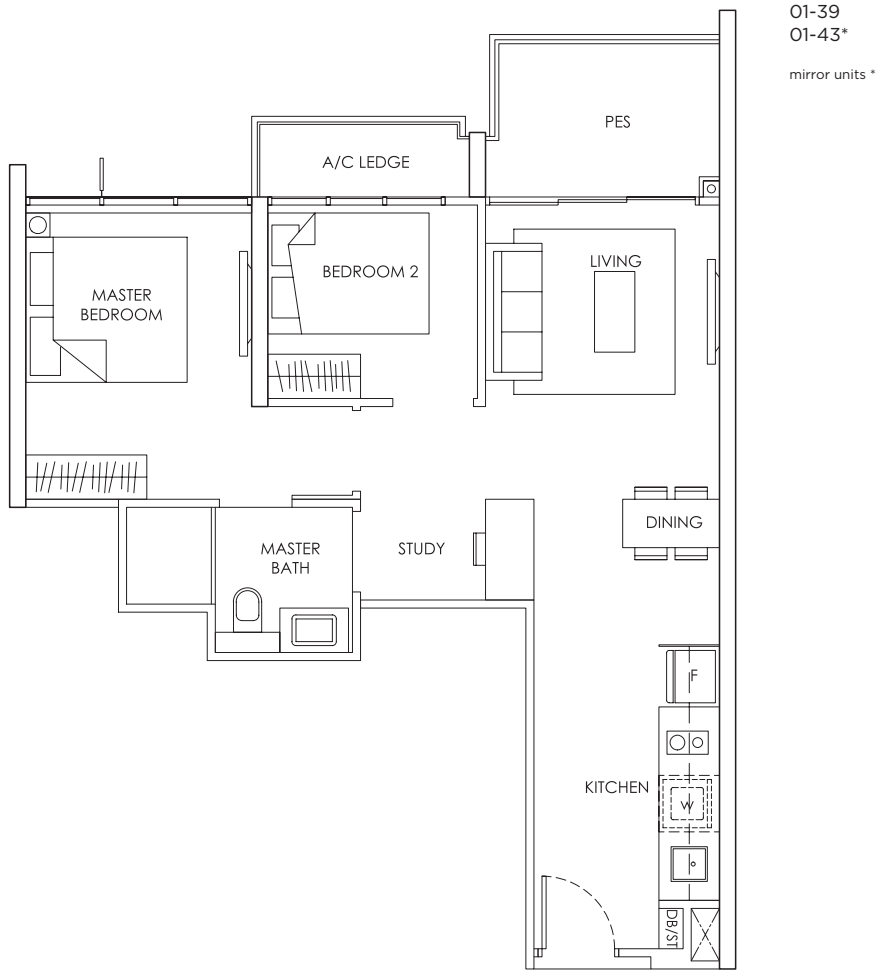

01-39
01-43*

mirror units *

KEY PLAN

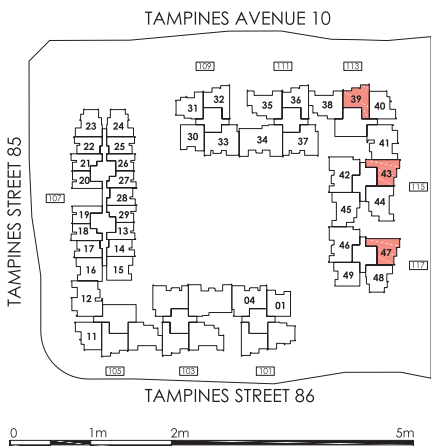

Area includes A/C ledge, balcony, PES, Roof Terrace and Void (where applicable). Orientation and facings will differ depending on the unit you are purchasing (please refer to key plan). All plans are not to scale and subject to changes as may be required by relevant authorities. All appliances and furniture shown in the plan are for illustration purpose only and not representation of fact. All floor areas are estimated and subjected to final survey.

Legend: F - Fridge DB/ST - Distribution Board and Storage space
WC - Water Closet W - Washer cum Dryer A/C - Aircon
PES - Private Enclosed Space

TYPE C1 (STACK 06 & 35)

3 - BEDROOM 87 sqm / 936 sqft

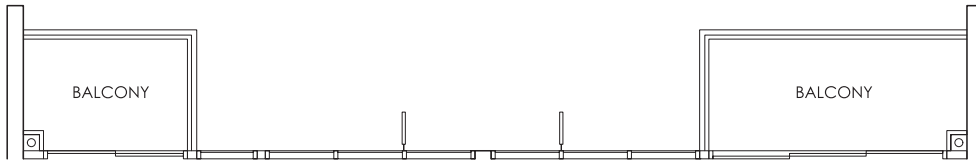

03-06, 12-06
05-35, 12-35

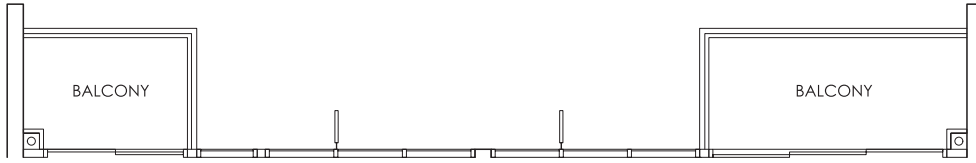

02-06, 09-06, 10-06
03-35, 10-35

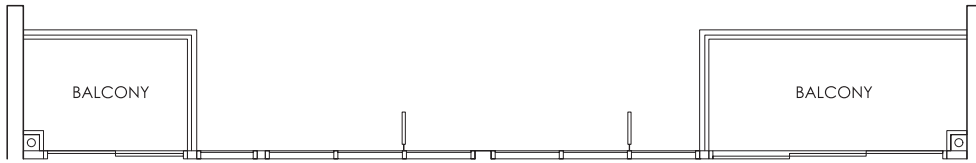

05-06, 06-06, 13-06
06-35

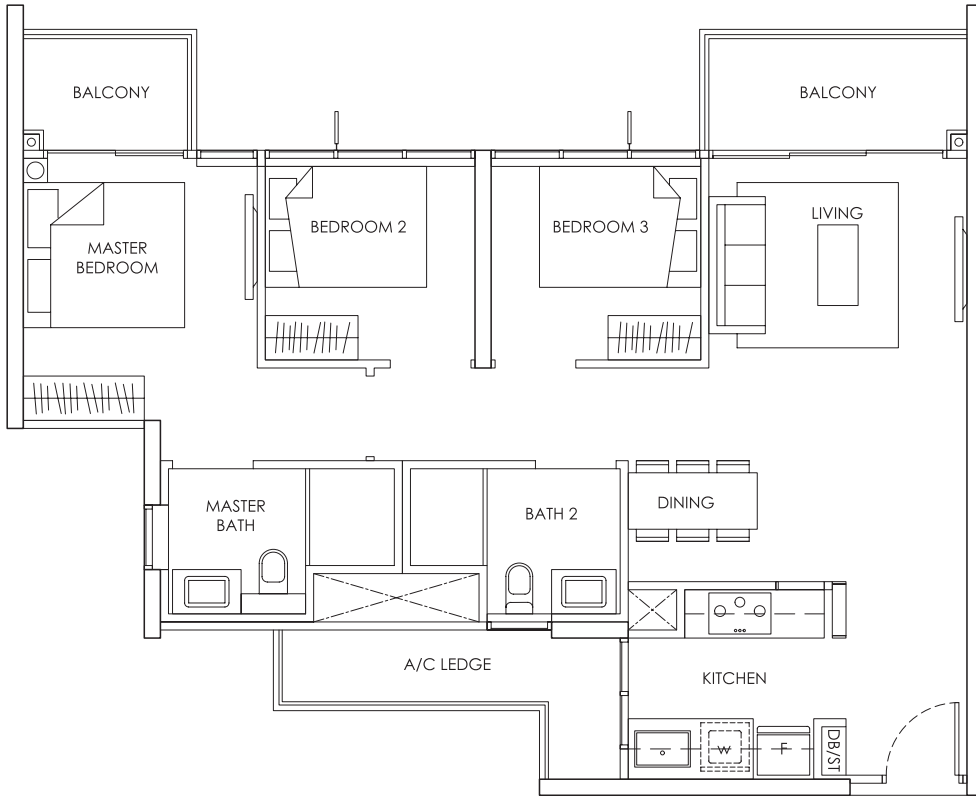

08-06
02-35, 08-35, 09-35

KEY PLAN

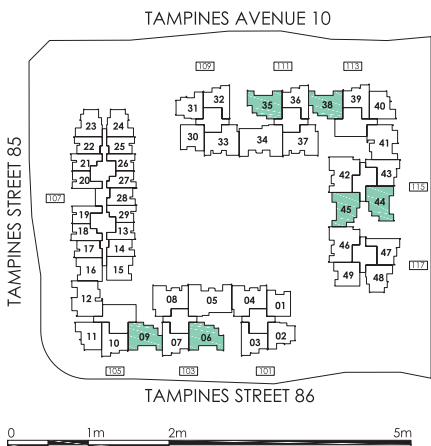

Area includes A/C ledge, balcony, PES, Roof Terrace and Void (where applicable). Orientation and facings will differ depending on the unit you are purchasing (please refer to key plan). All plans are not to scale and subject to changes as may be required by relevant authorities. All appliances and furniture shown in the plan are for illustration purpose only and not representation of fact. All floor areas are estimated and subjected to final survey.

Legend: F - Fridge DB/ST - Distribution Board and Storage space
WC - Water Closet W - Washer cum Dryer A/C - Aircon
PES - Private Enclosed Space

TYPE C1 (STACK 06 & 35)

3 - BEDROOM 87 sqm / 936 sqft

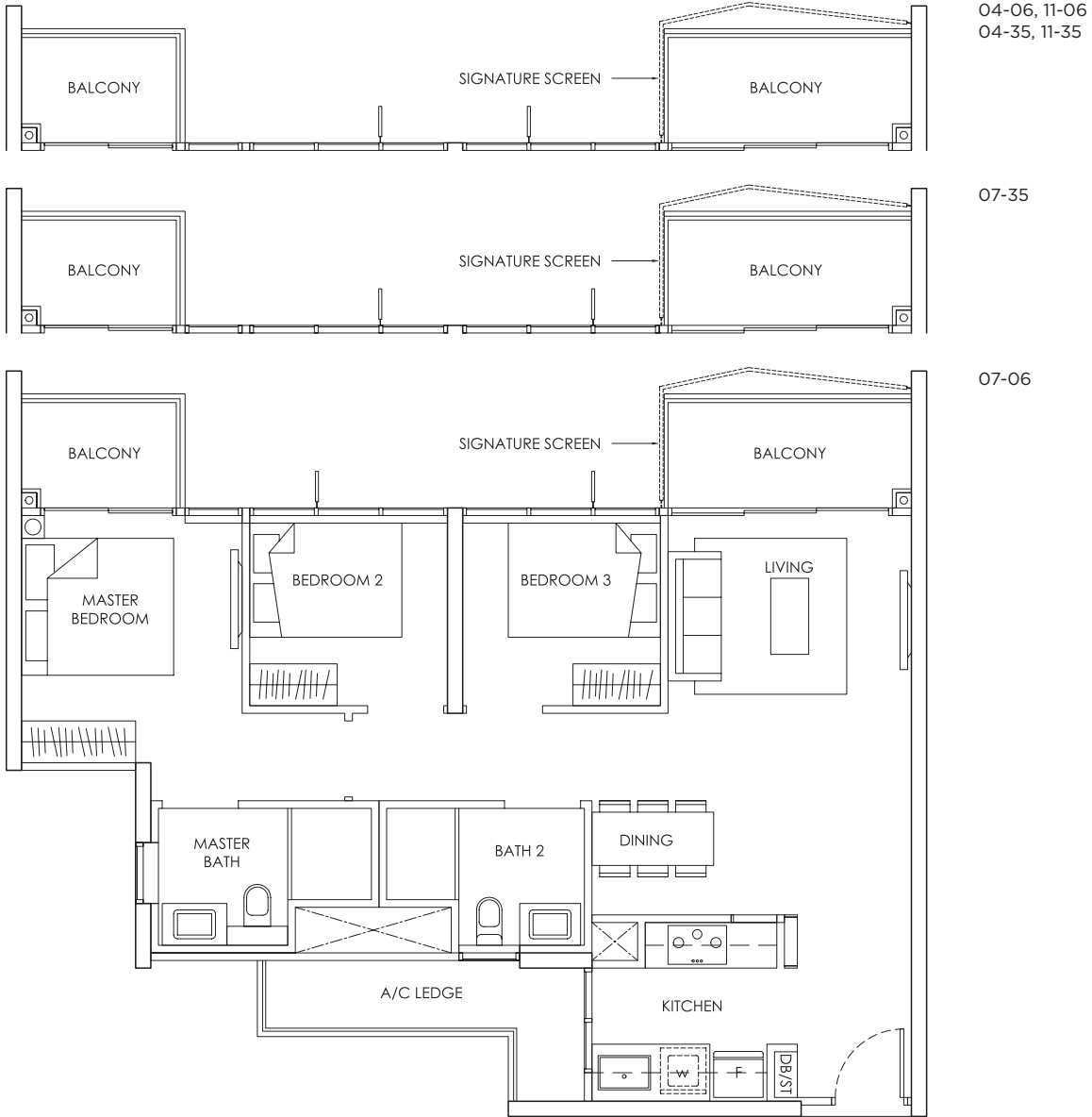

KEY PLAN

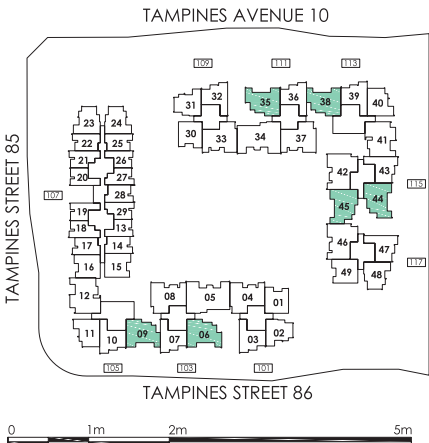

Area includes A/C ledge, balcony, PES, Roof Terrace and Void (where applicable). Orientation and facings will differ depending on the unit you are purchasing (please refer to key plan). All plans are not to scale and subject to changes as may be required by relevant authorities. All appliances and furniture shown in the plan are for illustration purpose only and not representation of fact. All floor areas are estimated and subjected to final survey.

- Legend: F - Fridge DB/ST - Distribution Board and Storage space
 WC - Water Closet W - Washer cum Dryer A/C - Aircon
 PES - Private Enclosed Space

TYPE C1 (STACK 09 & 38)

3 - BEDROOM 87 sqm / 936 sqft

06-09, 07-09

02-38, 07-38
08-38

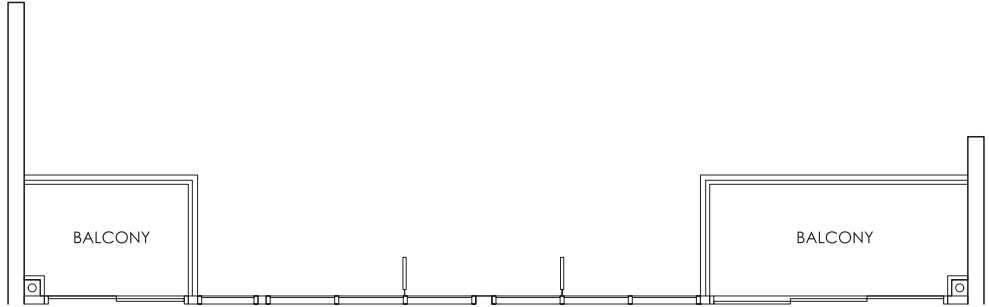

05-09, 12-09
13-09

06-38, 13-38

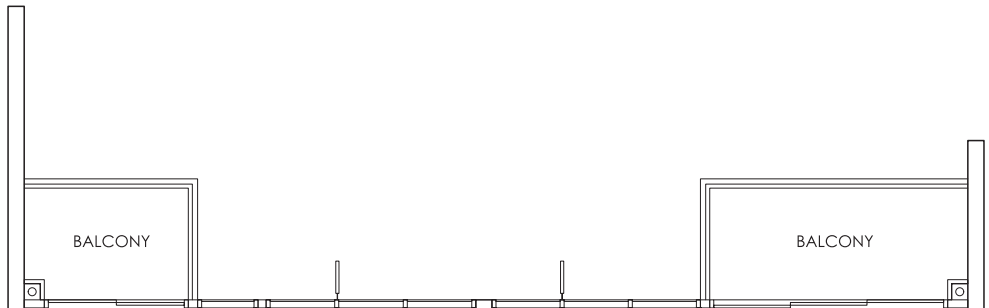

02-09, 08-09

03-38, 10-38

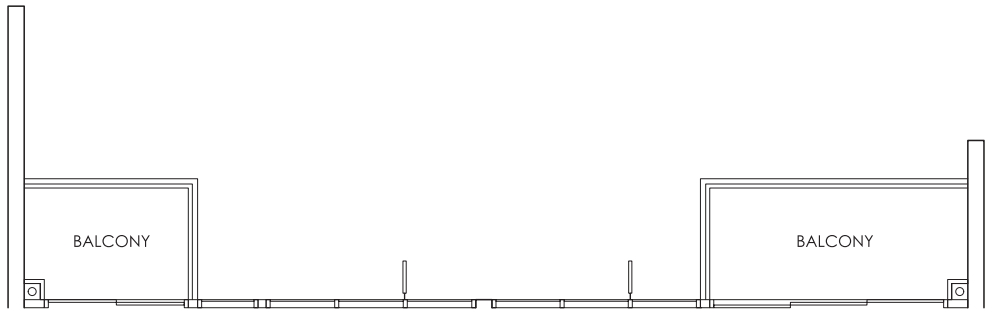

03-09, 10-09
11-09

05-38, 11-38
12-38

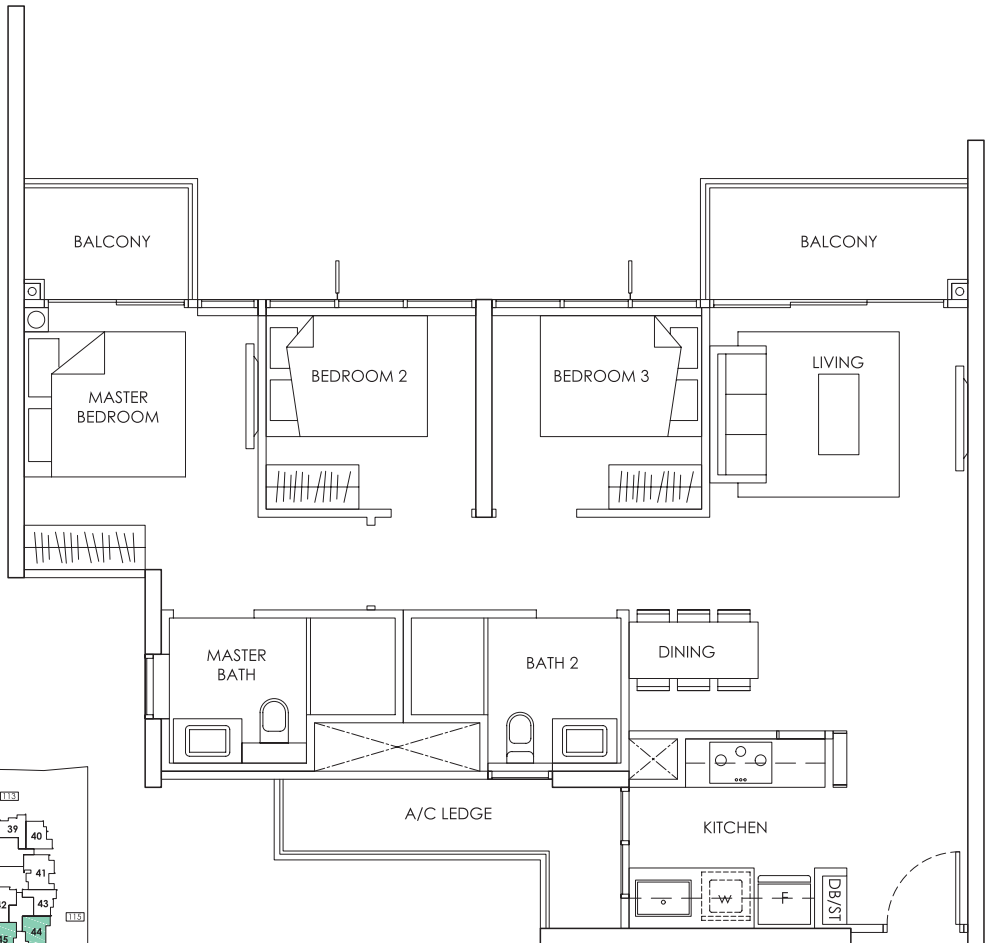

KEY PLAN

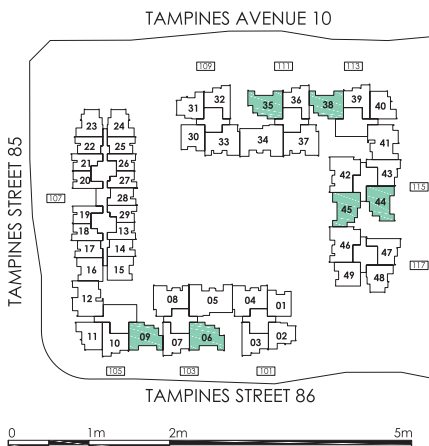

Area includes A/C ledge, balcony, PES, Roof Terrace and Void (where applicable). Orientation and facings will differ depending on the unit you are purchasing (please refer to key plan). All plans are not to scale and subject to changes as may be required by relevant authorities. All appliances and furniture shown in the plan are for illustration purpose only and not representation of fact. All floor areas are estimated and subjected to final survey.

Legend: F - Fridge DB/ST - Distribution Board and Storage space
WC - Water Closet W - Washer cum Dryer A/C - Aircon
PES - Private Enclosed Space

TYPE C1 (STACK 09 & 38)

3 - BEDROOM 87 sqm / 936 sqft

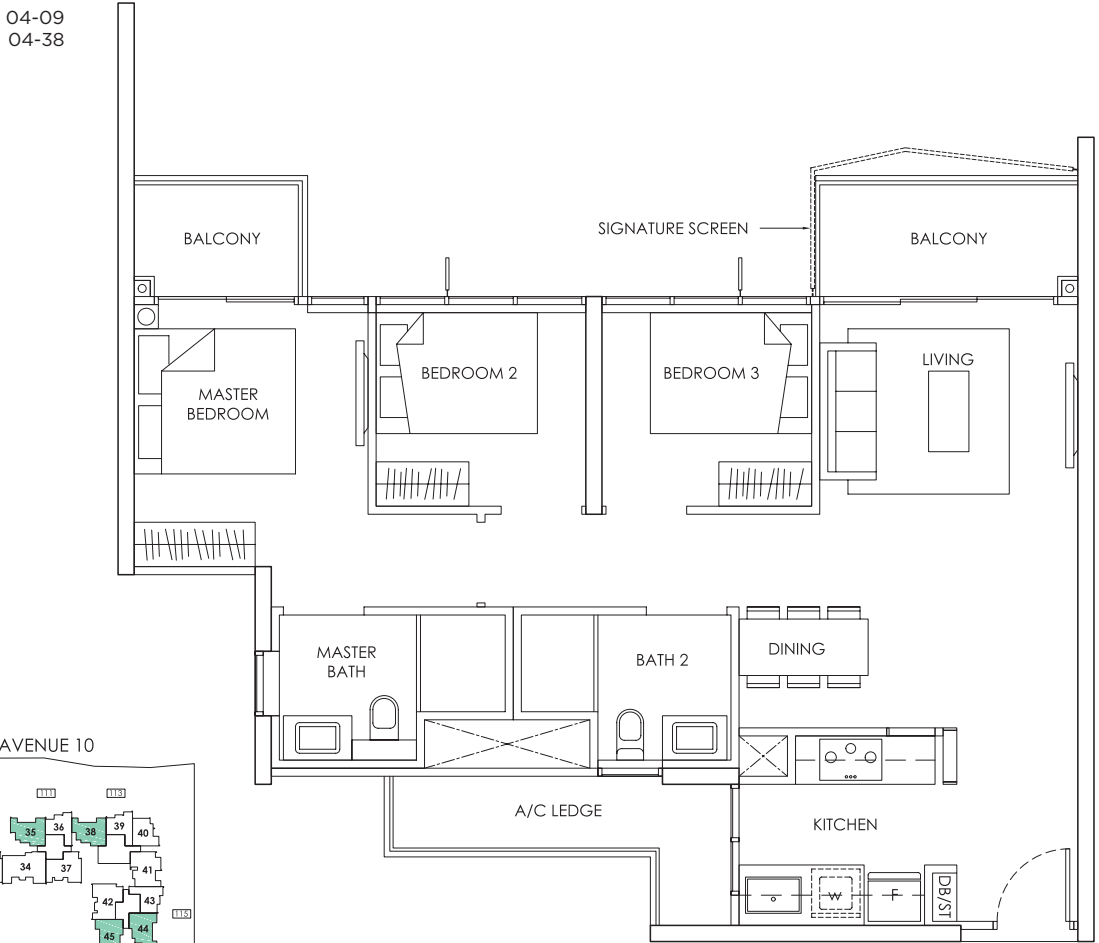
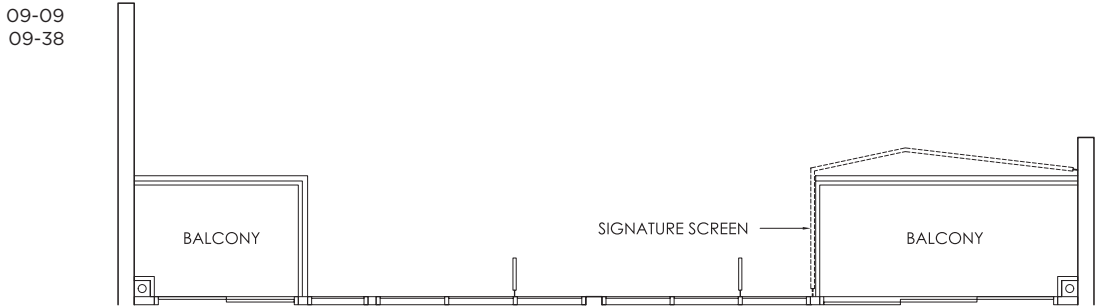
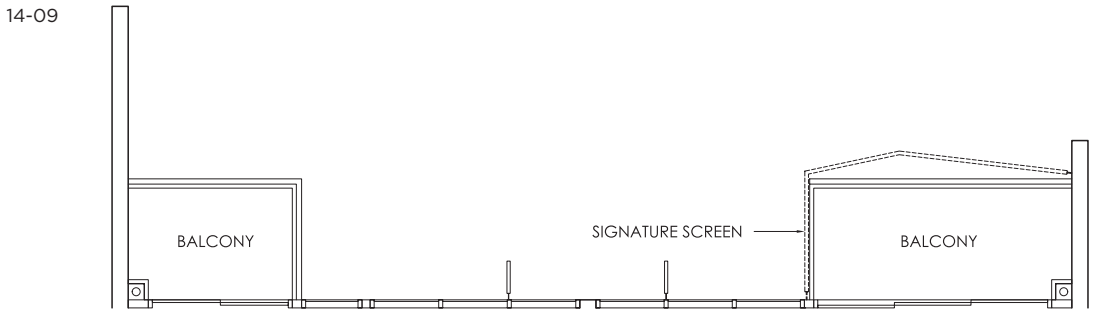
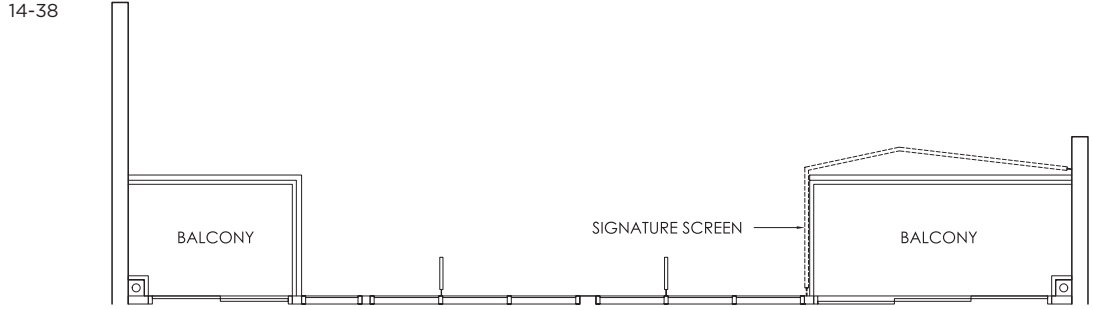

KEY PLAN

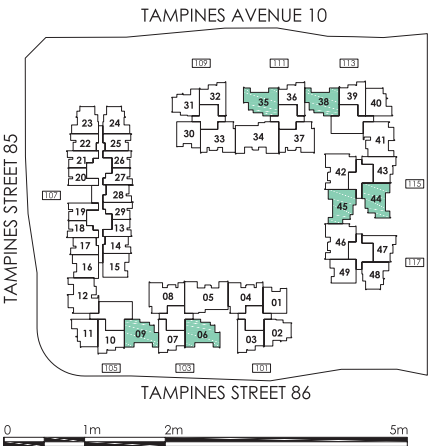

Area includes A/C ledge, balcony, PES, Roof Terrace and Void (where applicable). Orientation and facings will differ depending on the unit you are purchasing (please refer to key plan). All plans are not to scale and subject to changes as may be required by relevant authorities. All appliances and furniture shown in the plan are for illustration purpose only and not representation of fact. All floor areas are estimated and subjected to final survey.

- Legend:
- F - Fridge DB/ST - Distribution Board and Storage space
 - WC - Water Closet W - Washer cum Dryer A/C - Aircon
 - PES - Private Enclosed Space

TYPE C1 (STACK 44)

3 - BEDROOM 87 sqm / 936 sqft

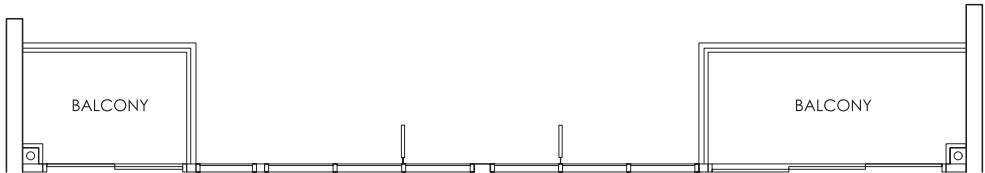

02-44*, 07-44*
08-44*, 14-44*

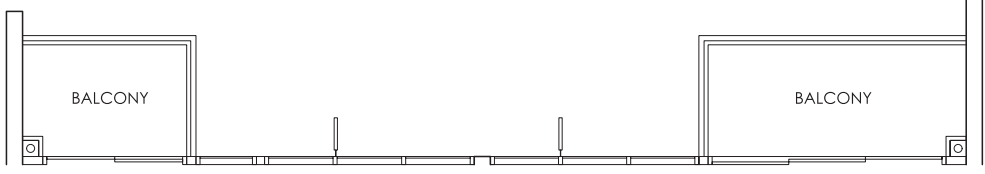

06-44*

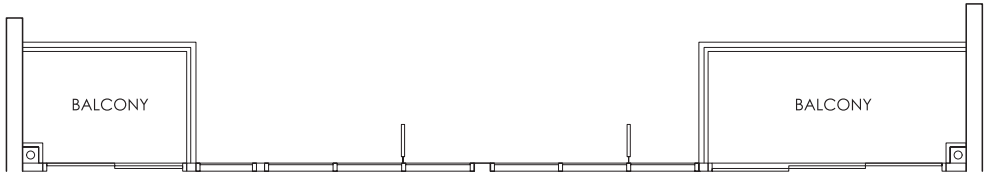

03-44*, 09-44*

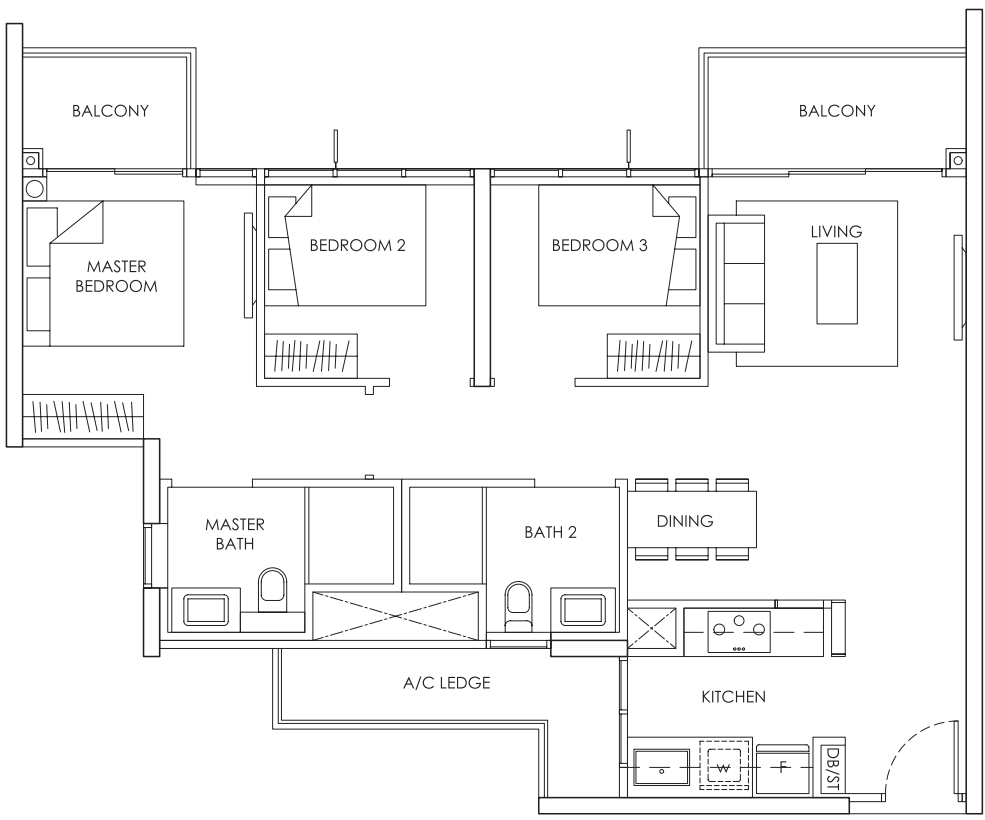

04-44*, 11-44*
12-44*
mirror units *

KEY PLAN

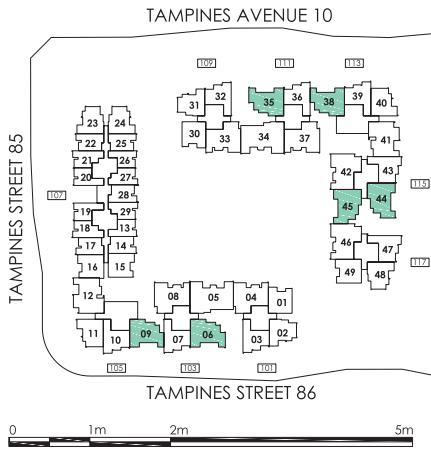

Area includes A/C ledge, balcony, PES, Roof Terrace and Void (where applicable). Orientation and facings will differ depending on the unit you are purchasing (please refer to key plan). All plans are not to scale and subject to changes as may be required by relevant authorities. All appliances and furniture shown in the plan are for illustration purpose only and not representation of fact. All floor areas are estimated and subjected to final survey.

- Legend:
- F - Fridge
 - WC - Water Closet
 - PES - Private Enclosed Space
 - DB/ST - Distribution Board and Storage space
 - W - Washer cum Dryer
 - A/C - Aircon

TYPE C1 (STACK 44)

3 - BEDROOM 87 sqm / 936 sqft

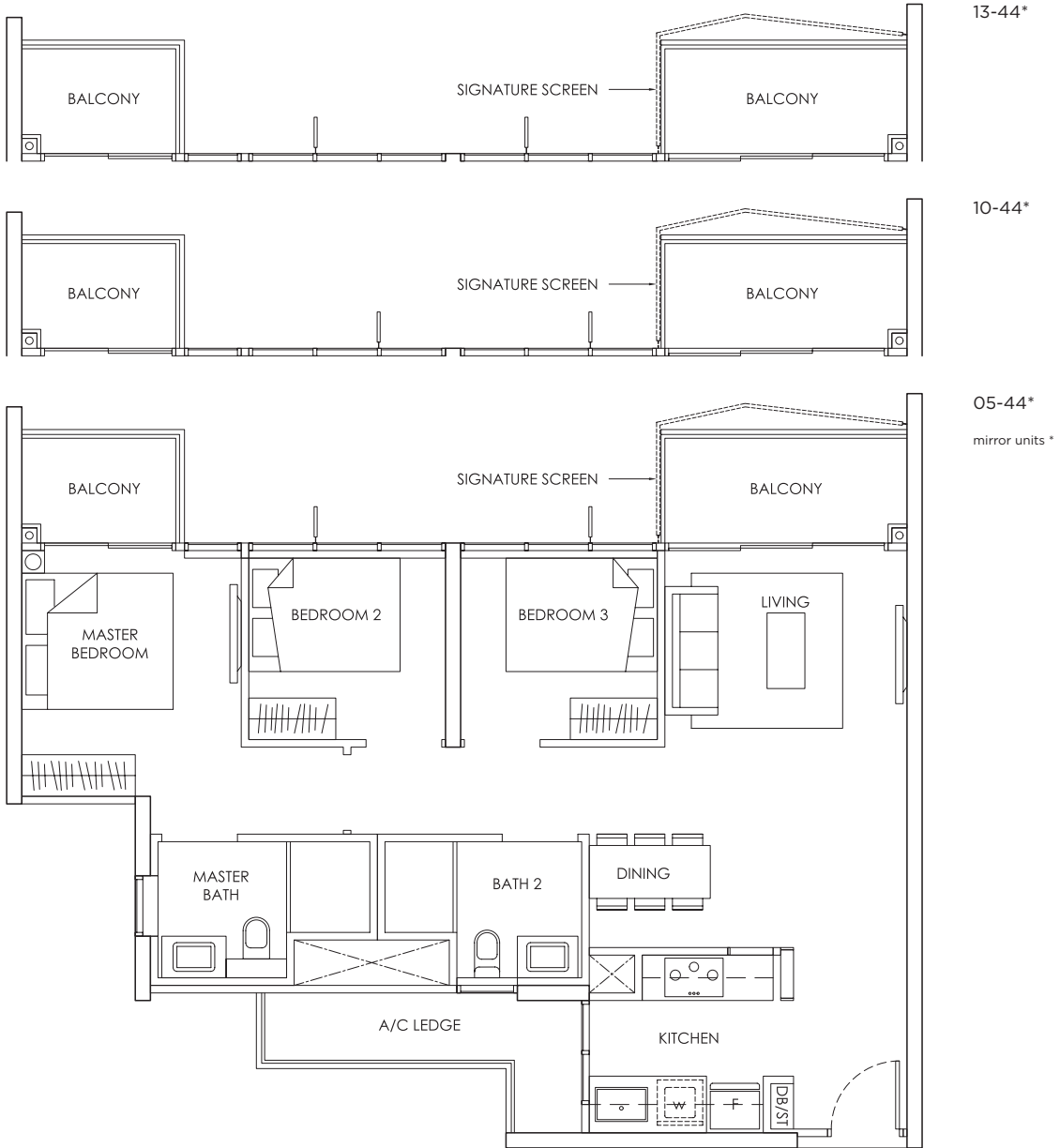

KEY PLAN

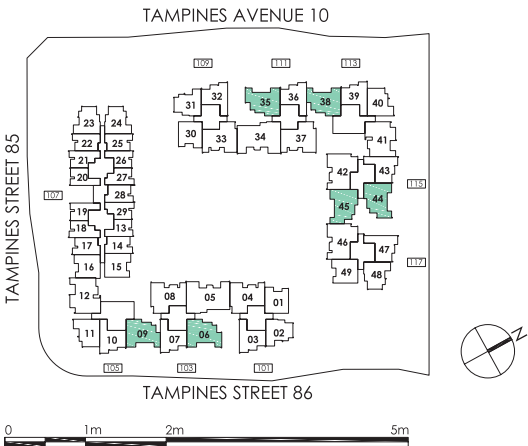

Area includes A/C ledge, balcony, PES, Roof Terrace and Void (where applicable). Orientation and facings will differ depending on the unit you are purchasing (please refer to key plan). All plans are not to scale and subject to changes as may be required by relevant authorities. All appliances and furniture shown in the plan are for illustration purpose only and not representation of fact. All floor areas are estimated and subjected to final survey.

- Legend: F - Fridge DB/ST - Distribution Board and Storage space
 WC - Water Closet W - Washer cum Dryer A/C - Aircon
 PES - Private Enclosed Space

TYPE C1 (STACK 45)

3 - BEDROOM 87 sqm / 936 sqft

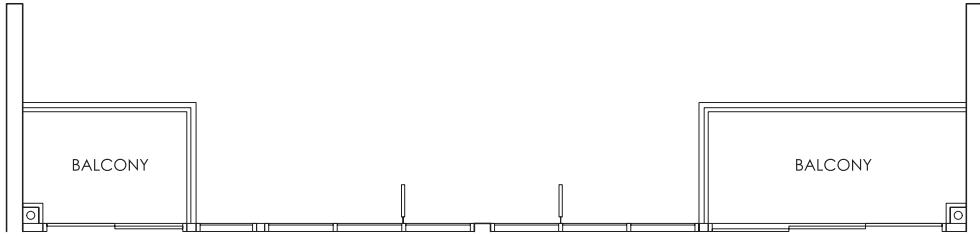

07-45, 14-45

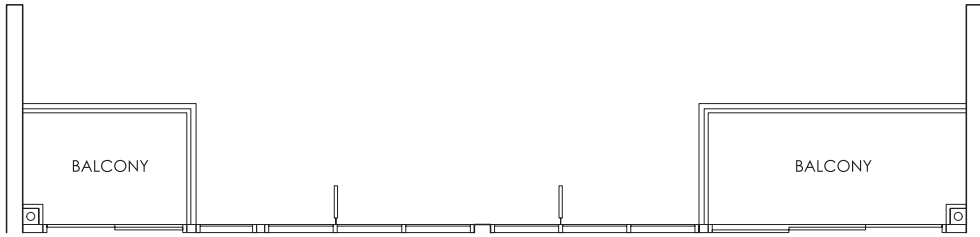

05-45, 12-45
13-45

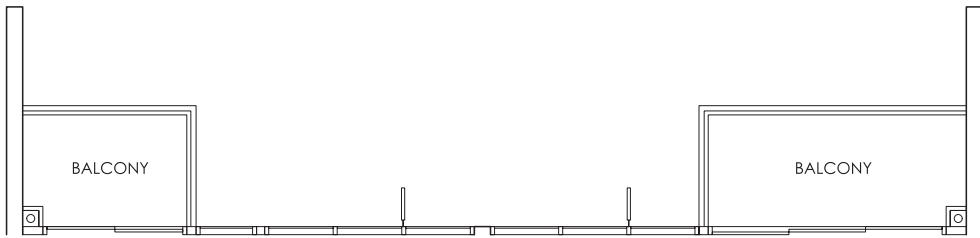

02-45, 08-45
09-45

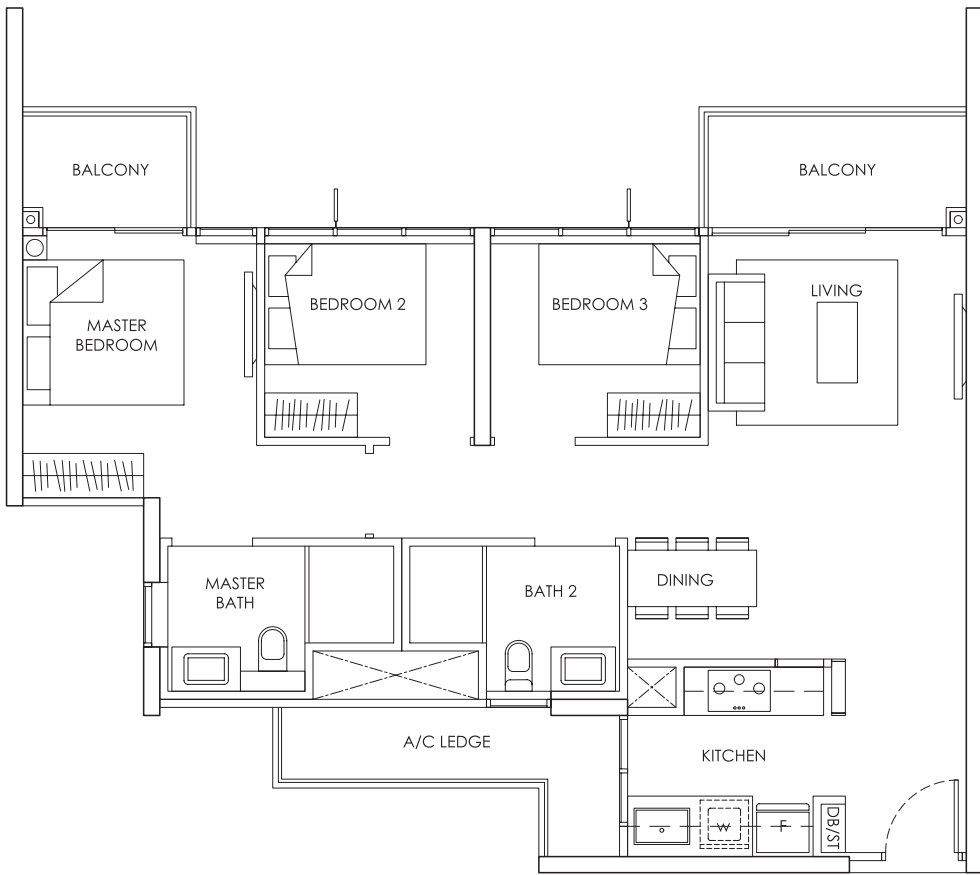

04-45, 10-45

KEY PLAN

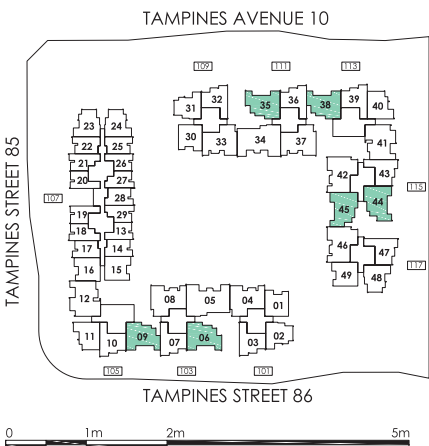

Area includes A/C ledge, balcony, PES, Roof Terrace and Void (where applicable). Orientation and facings will differ depending on the unit you are purchasing (please refer to key plan). All plans are not to scale and subject to changes as may be required by relevant authorities. All appliances and furniture shown in the plan are for illustration purpose only and not representation of fact. All floor areas are estimated and subjected to final survey.

Legend: F - Fridge DB/ST - Distribution Board and Storage space
WC - Water Closet W - Washer cum Dryer A/C - Aircon
PES - Private Enclosed Space

TYPE C1 (STACK 45)

3 - BEDROOM 87 sqm / 936 sqft

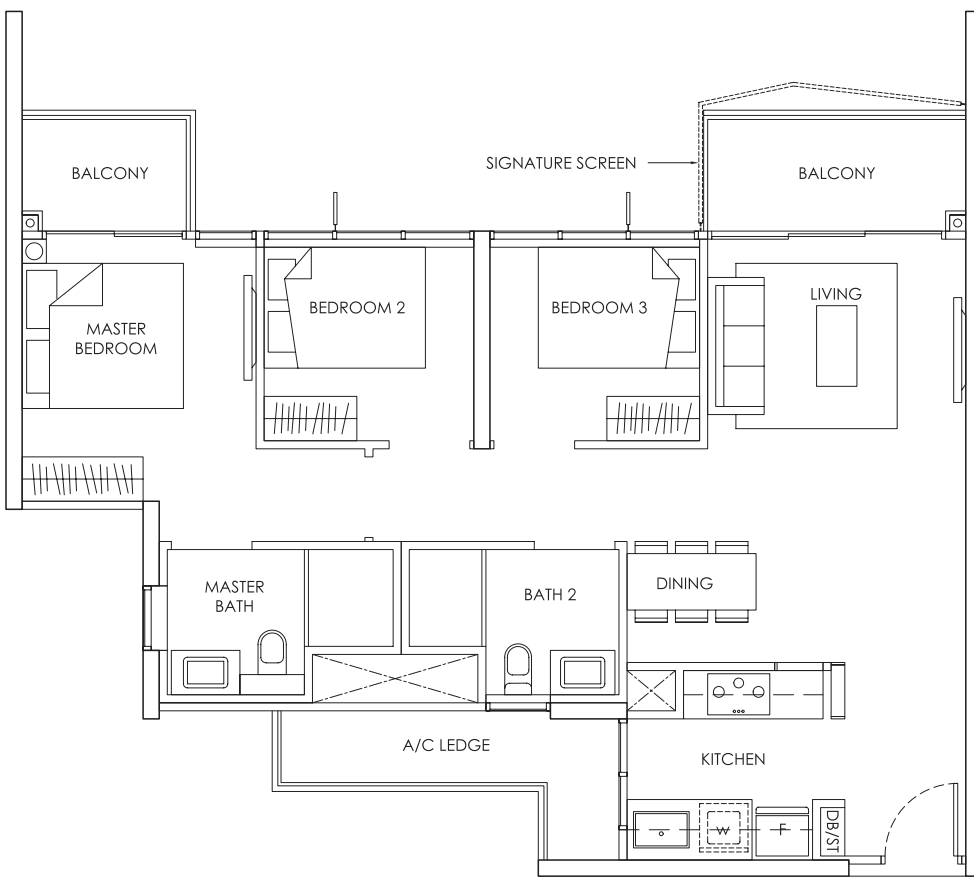
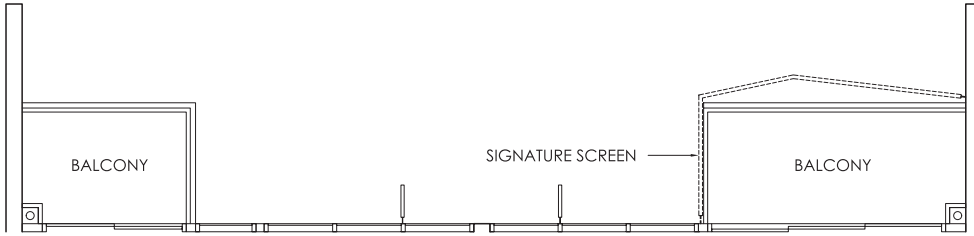

KEY PLAN

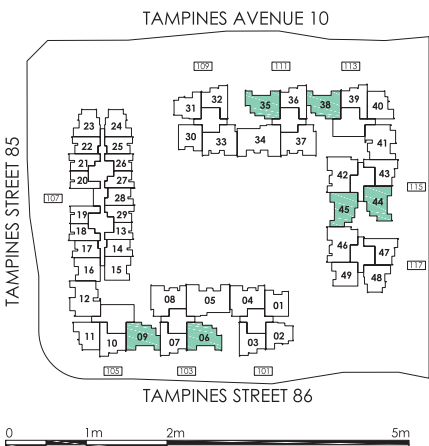

Area includes A/C ledge, balcony, PES, Roof Terrace and Void (where applicable). Orientation and facings will differ depending on the unit you are purchasing (please refer to key plan). All plans are not to scale and subject to changes as may be required by relevant authorities. All appliances and furniture shown in the plan are for illustration purpose only and not representation of fact. All floor areas are estimated and subjected to final survey.

- Legend:
- F - Fridge
 - DB/ST - Distribution Board and Storage space
 - WC - Water Closet
 - W - Washer cum Dryer
 - A/C - Aircon
 - PES - Private Enclosed Space

TYPE C1-P

3 - BEDROOM 87 sqm / 936 sqft

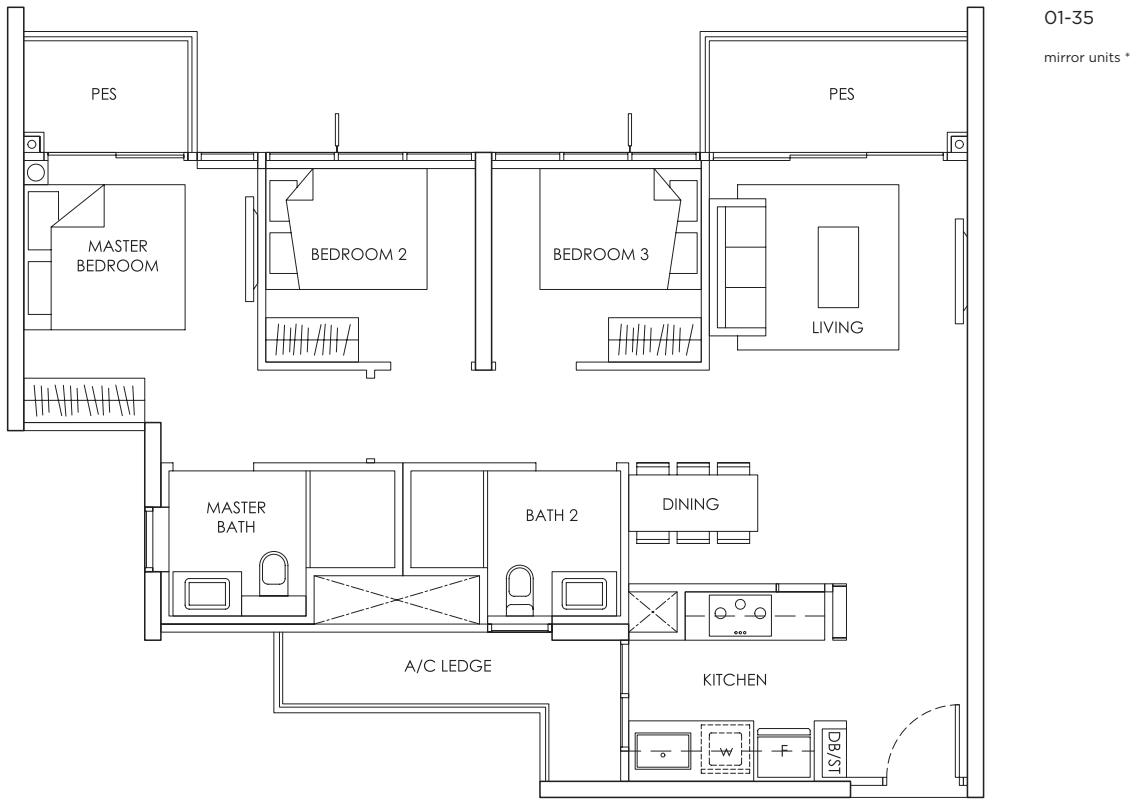
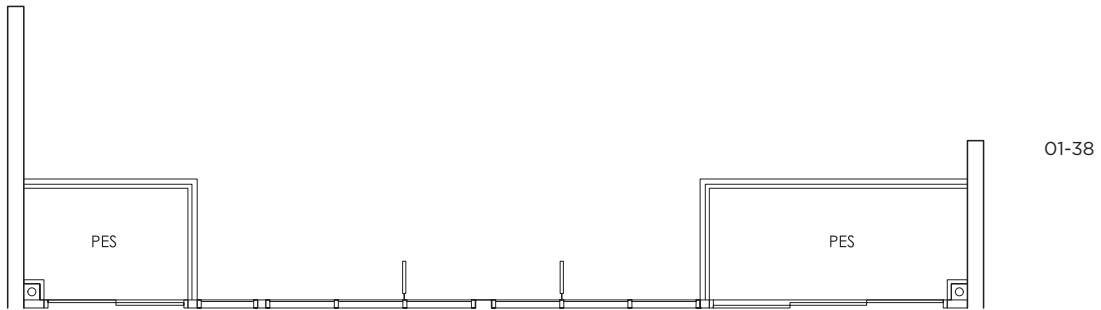
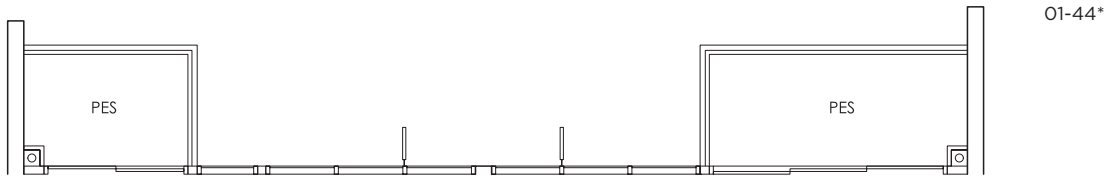
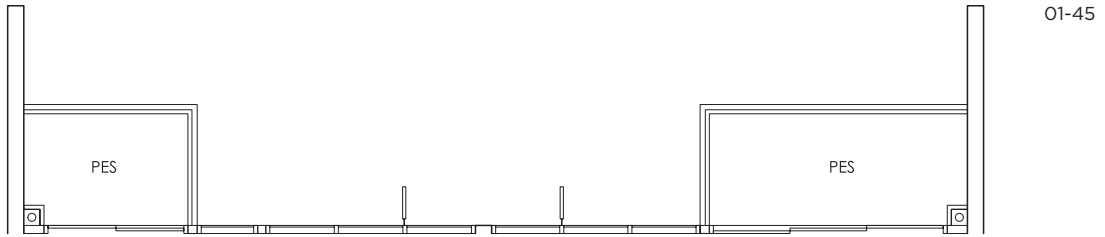

KEY PLAN

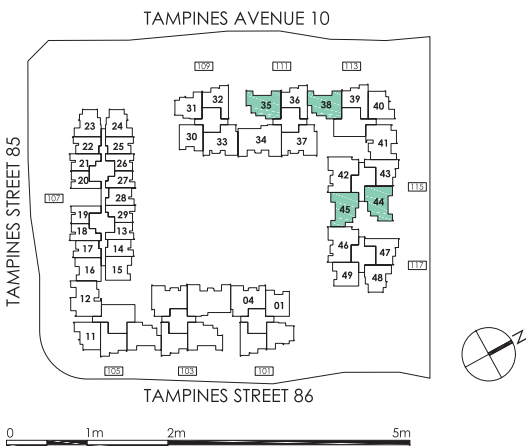

Area includes A/C ledge, balcony, PES, Roof Terrace and Void (where applicable). Orientation and facings will differ depending on the unit you are purchasing (please refer to key plan). All plans are not to scale and subject to changes as may be required by relevant authorities. All appliances and furniture shown in the plan are for illustration purpose only and not representation of fact. All floor areas are estimated and subjected to final survey.

- Legend: F - Fridge DB/ST - Distribution Board and Storage space
WC - Water Closet W - Washer cum Dryer A/C - Aircon
PES - Private Enclosed Space

TYPE C2 & C2-P

(Stack 04 & 33)

3 - BEDROOM 99 sqm / 1,066 sqft

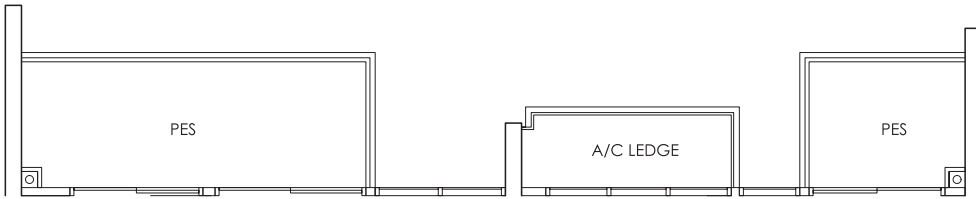

01-04
01-33

C2-P

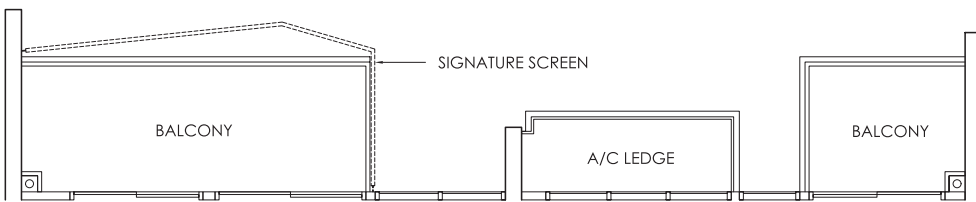

04-04, 07-04
04-33, 07-33, 09-33

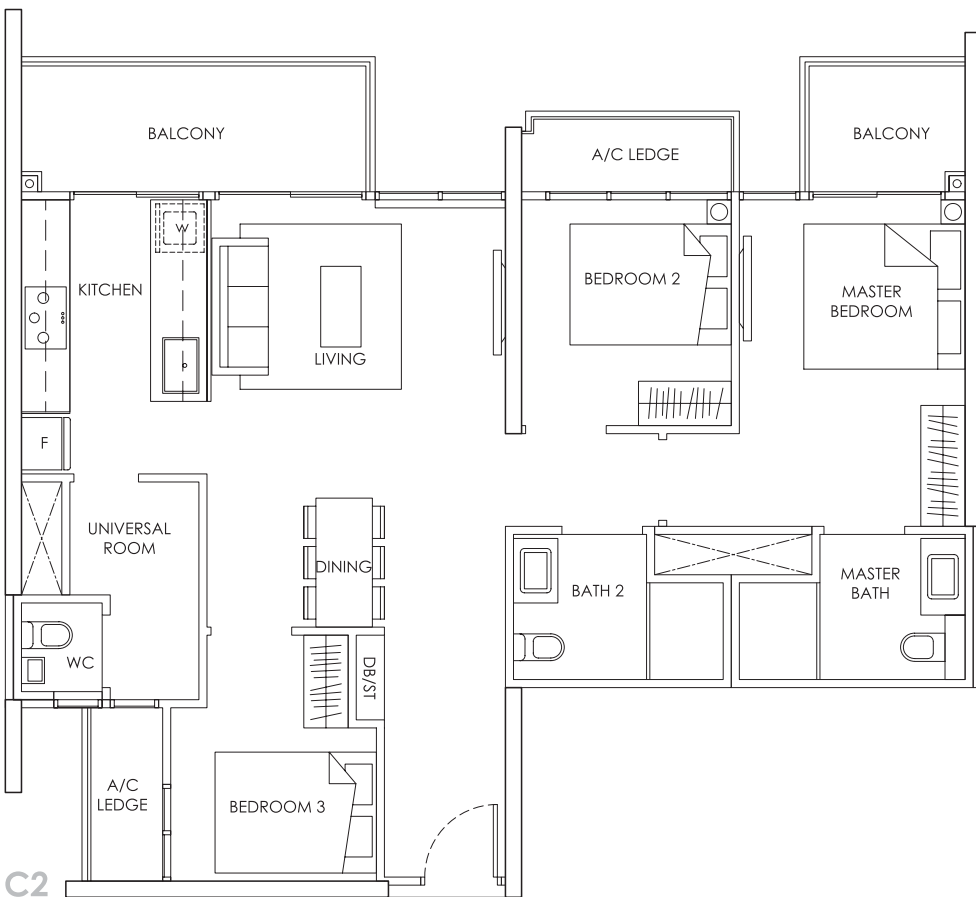

02-04, 03-04, 05-04
06-04, 08-04 to 10-04

02-33, 03-33, 05-33
06-33, 08-33, 10-33

C2

KEY PLAN

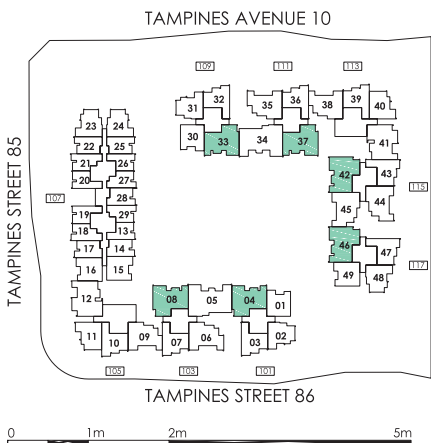

Area includes A/C ledge, balcony, PES, Roof Terrace and Void (where applicable). Orientation and facings will differ depending on the unit you are purchasing (please refer to key plan). All plans are not to scale and subject to changes as may be required by relevant authorities. All appliances and furniture shown in the plan are for illustration purpose only and not representation of fact. All floor areas are estimated and subjected to final survey.

Legend: F - Fridge DB/ST - Distribution Board and Storage space
WC - Water Closet W - Washer cum Dryer A/C - Aircon
PES - Private Enclosed Space

TYPE C2 & C2-P

(STACK 08 & 37)

3 - BEDROOM 99 sqm / 1,066 sqft

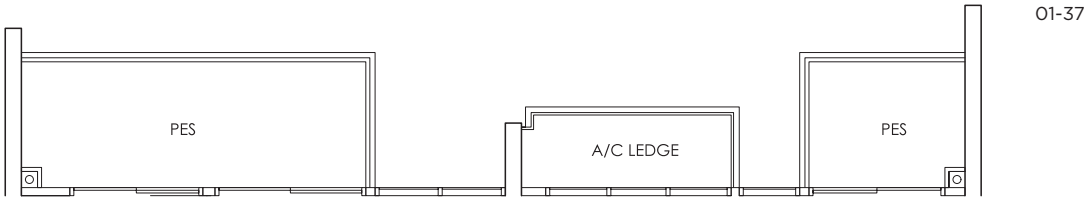

C2-P

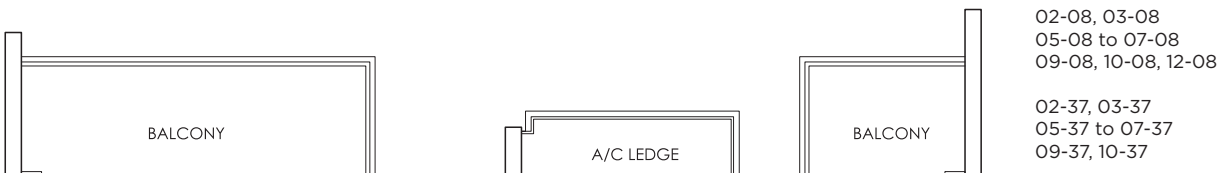
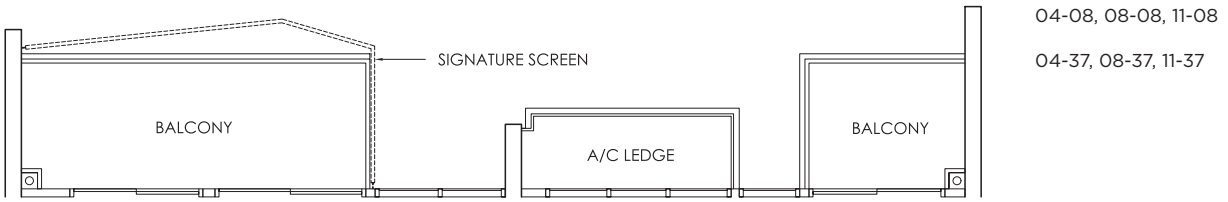

C2

KEY PLAN

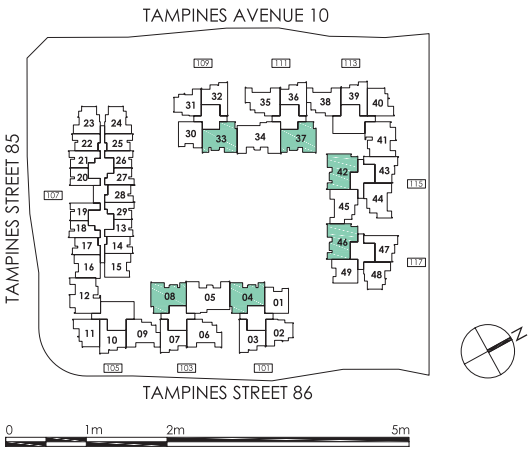

Area includes A/C ledge, balcony, PES, Roof Terrace and Void (where applicable). Orientation and facings will differ depending on the unit you are purchasing (please refer to key plan). All plans are not to scale and subject to changes as may be required by relevant authorities. All appliances and furniture shown in the plan are for illustration purpose only and not representation of fact. All floor areas are estimated and subjected to final survey.

- Legend:
- F - Fridge
 - DB/ST - Distribution Board and Storage space
 - WC - Water Closet
 - W - Washer cum Dryer
 - A/C - Aircon
 - PES - Private Enclosed Space

TYPE C2 & C2-P (STACK 42 & 46)

3 - BEDROOM 99 sqm / 1,066 sqft

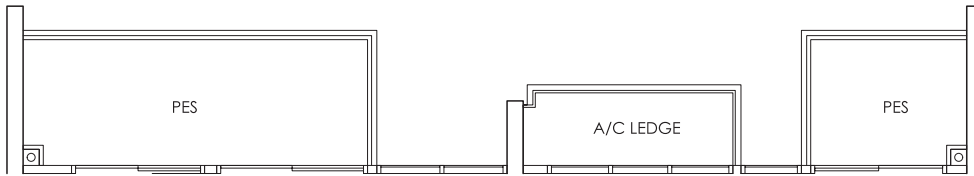

01-42*
01-46*

C2-P

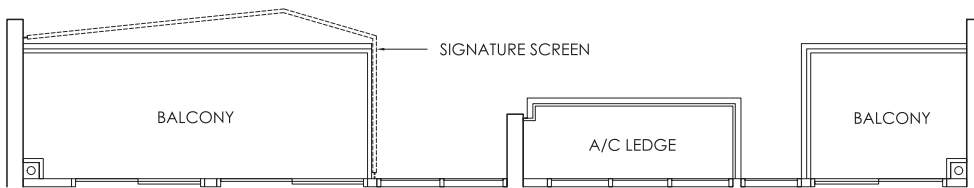

04-42*, 08-42*, 14-42*
04-46*, 10-46*, 12-46*

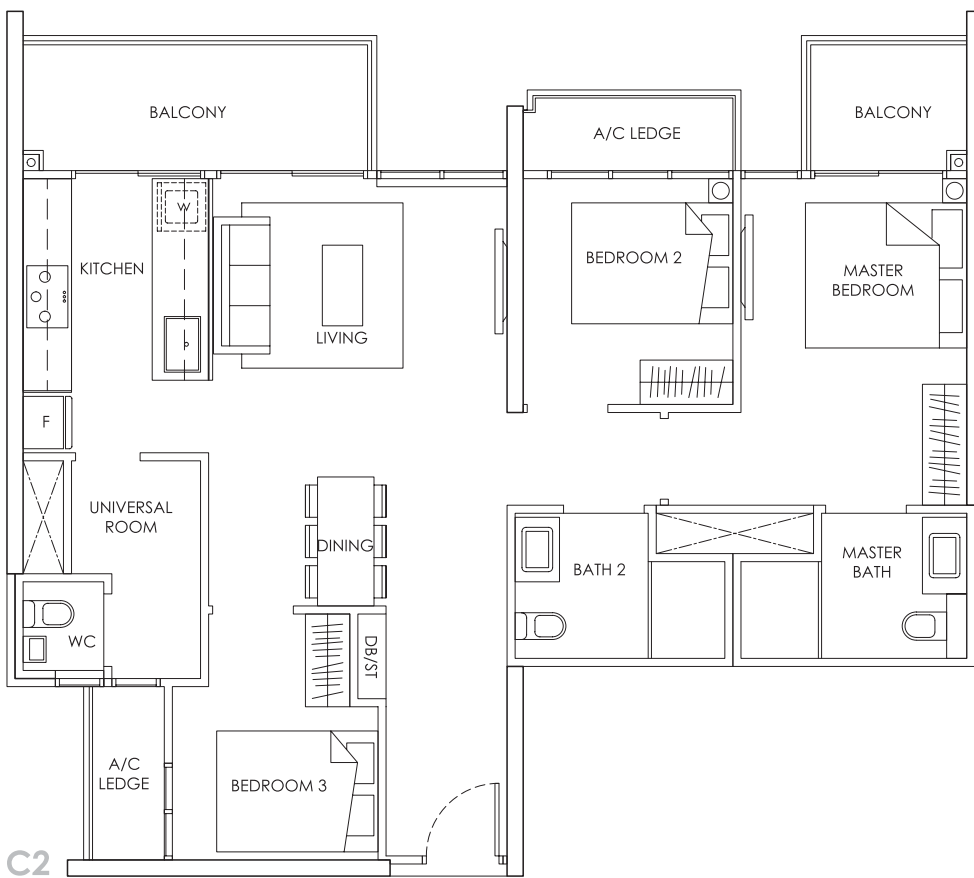

02-42*, 03-42*
05-42* to 07-42*
09-42* to 13-42*

02-42*, 03-46*
05-46* to 09-46*
11-46*, 13-46*

mirror units*

C2

KEY PLAN

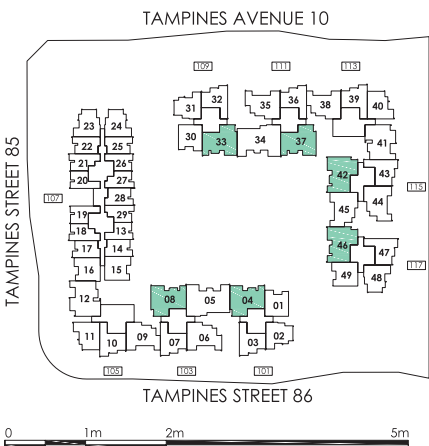

Area includes A/C ledge, balcony, PES, Roof Terrace and Void (where applicable). Orientation and facings will differ depending on the unit you are purchasing (please refer to key plan). All plans are not to scale and subject to changes as may be required by relevant authorities. All appliances and furniture shown in the plan are for illustration purpose only and not representation of fact. All floor areas are estimated and subjected to final survey.

Legend: F - Fridge DB/ST - Distribution Board and Storage space
WC - Water Closet W - Washer cum Dryer A/C - Aircon
PES - Private Enclosed Space

TYPE C3 (STACK 12)

3 - BEDROOM 101 sqm / 1,087 sqft

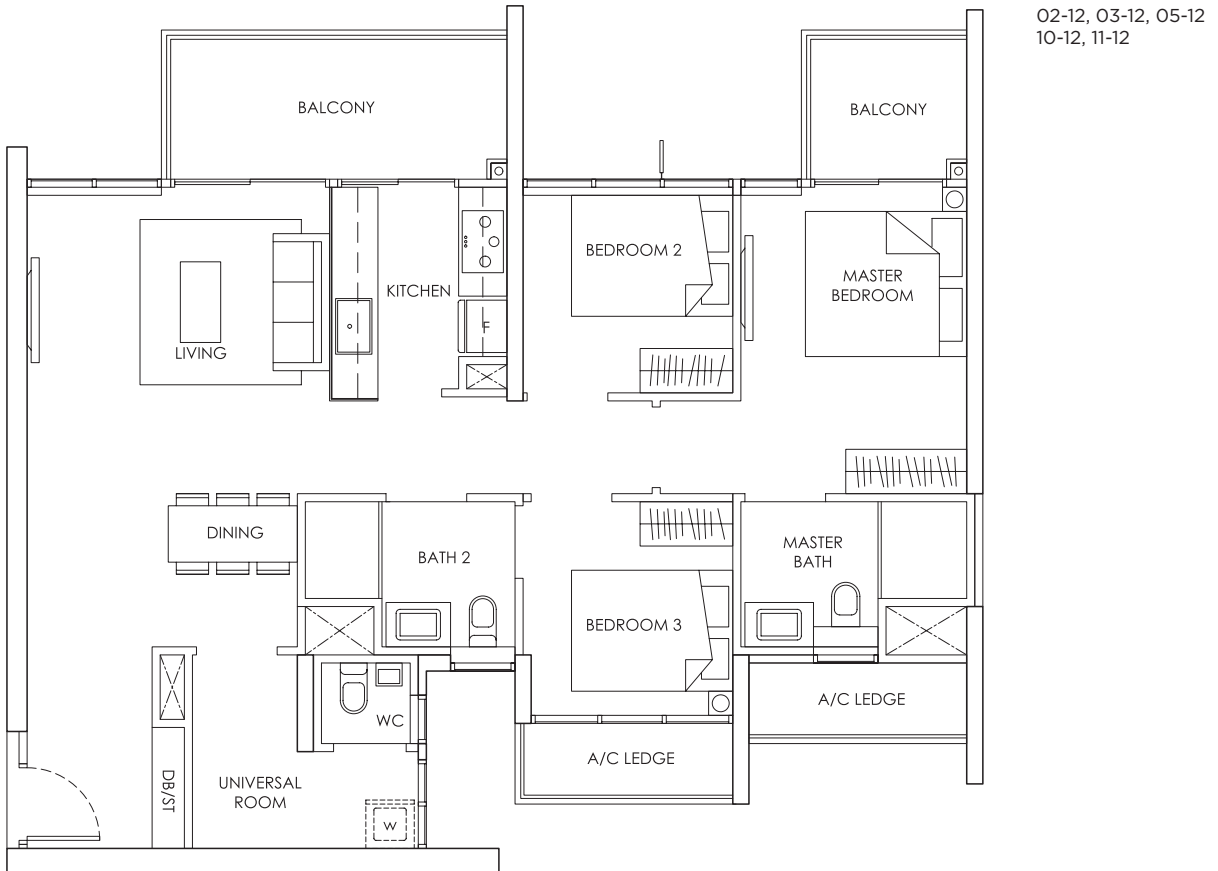
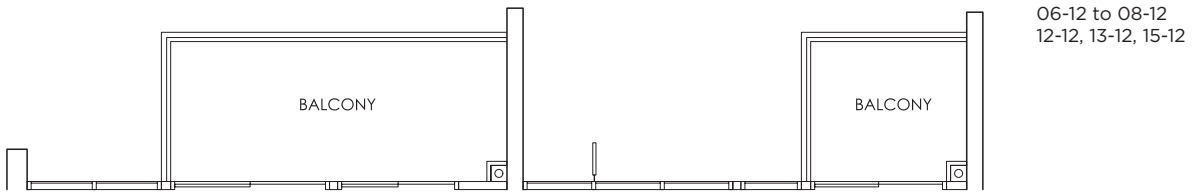
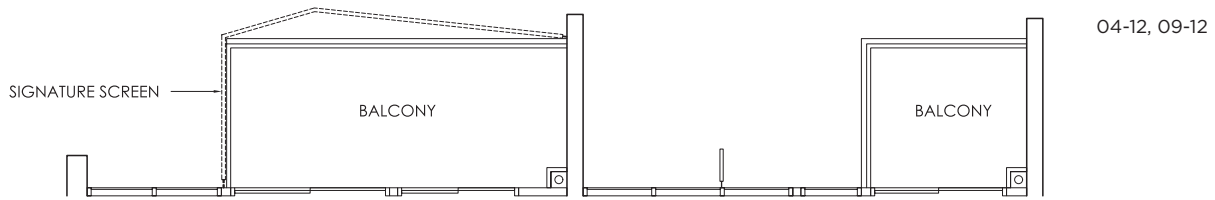
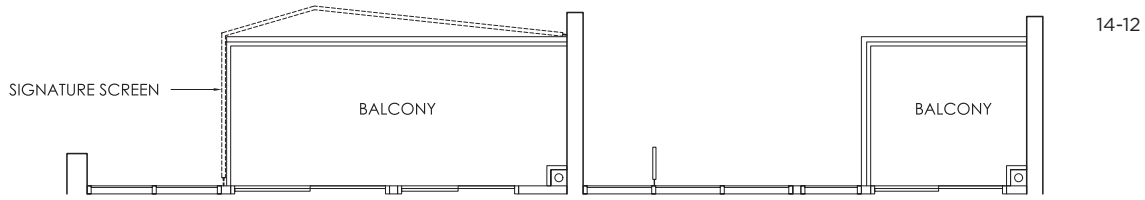

KEY PLAN

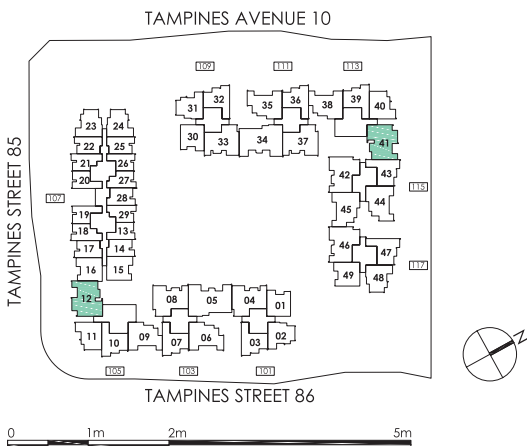

Area includes A/C ledge, balcony, PES, Roof Terrace and Void (where applicable). Orientation and facings will differ depending on the unit you are purchasing (please refer to key plan). All plans are not to scale and subject to changes as may be required by relevant authorities. All appliances and furniture shown in the plan are for illustration purpose only and not representation of fact. All floor areas are estimated and subjected to final survey.

Legend: F - Fridge DB/ST - Distribution Board and Storage space
WC - Water Closet W - Washer cum Dryer A/C - Aircon
PES - Private Enclosed Space

TYPE C3 (STACK 41)

3 - BEDROOM 101 sqm / 1,087 sqft

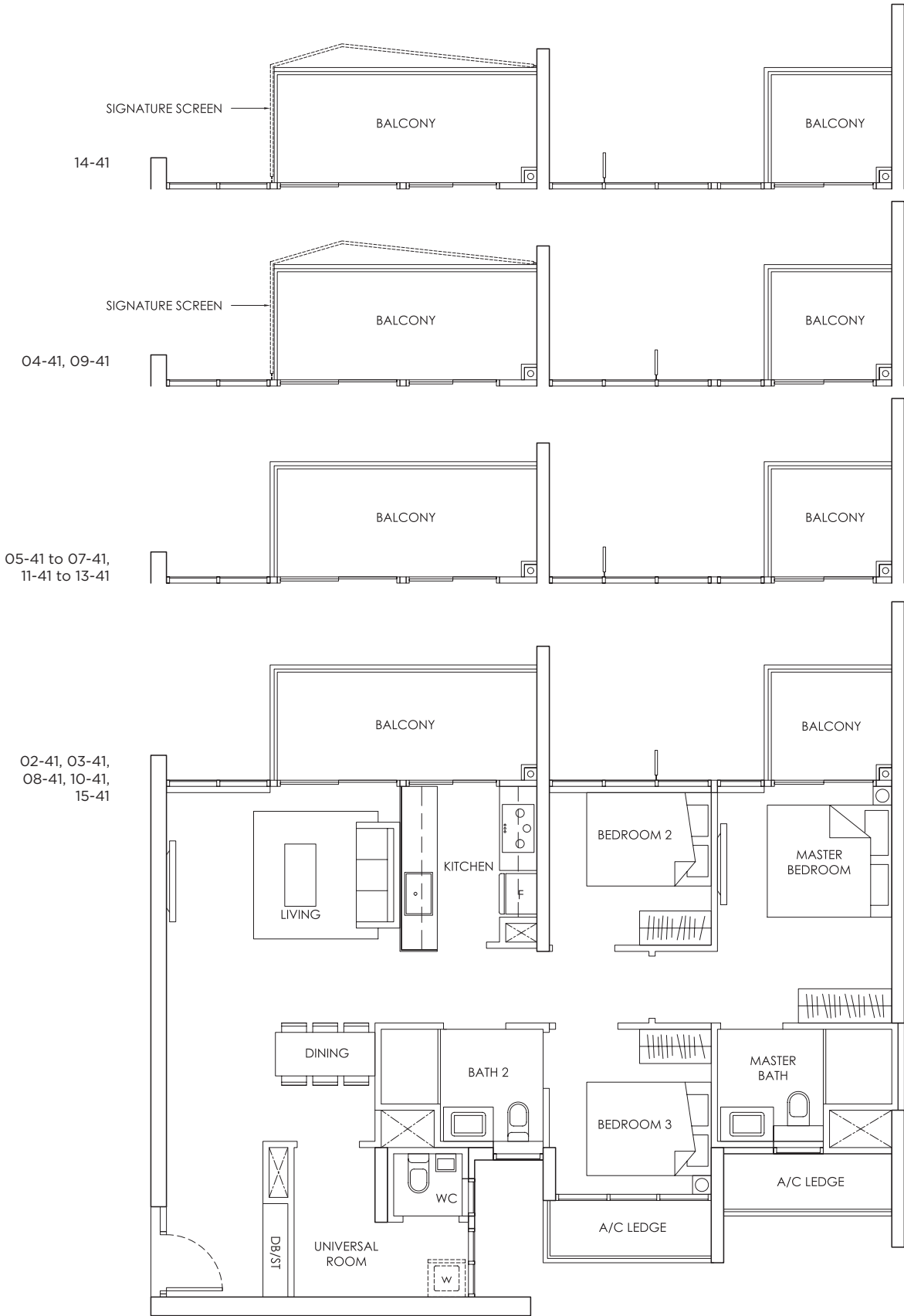

KEY PLAN

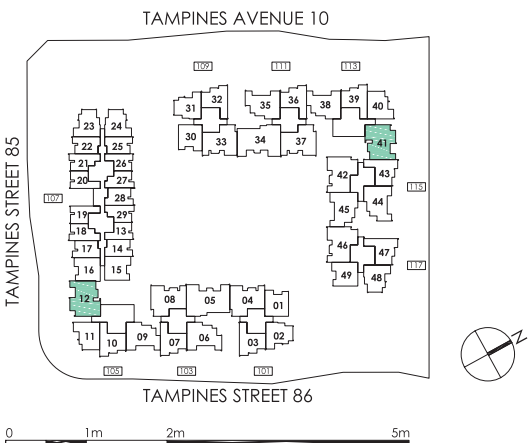

Area includes A/C ledge, balcony, PES, Roof Terrace and Void (where applicable). Orientation and facings will differ depending on the unit you are purchasing (please refer to key plan). All plans are not to scale and subject to changes as may be required by relevant authorities. All appliances and furniture shown in the plan are for illustration purpose only and not representation of fact. All floor areas are estimated and subjected to final survey.

- Legend: **F** - Fridge **DB/ST** - Distribution Board and Storage space
WC - Water Closet **W** - Washer cum Dryer **A/C** - Aircon
PES - Private Enclosed Space

TYPE C3-P

3 - BEDROOM 101 sqm / 1,087 sqft

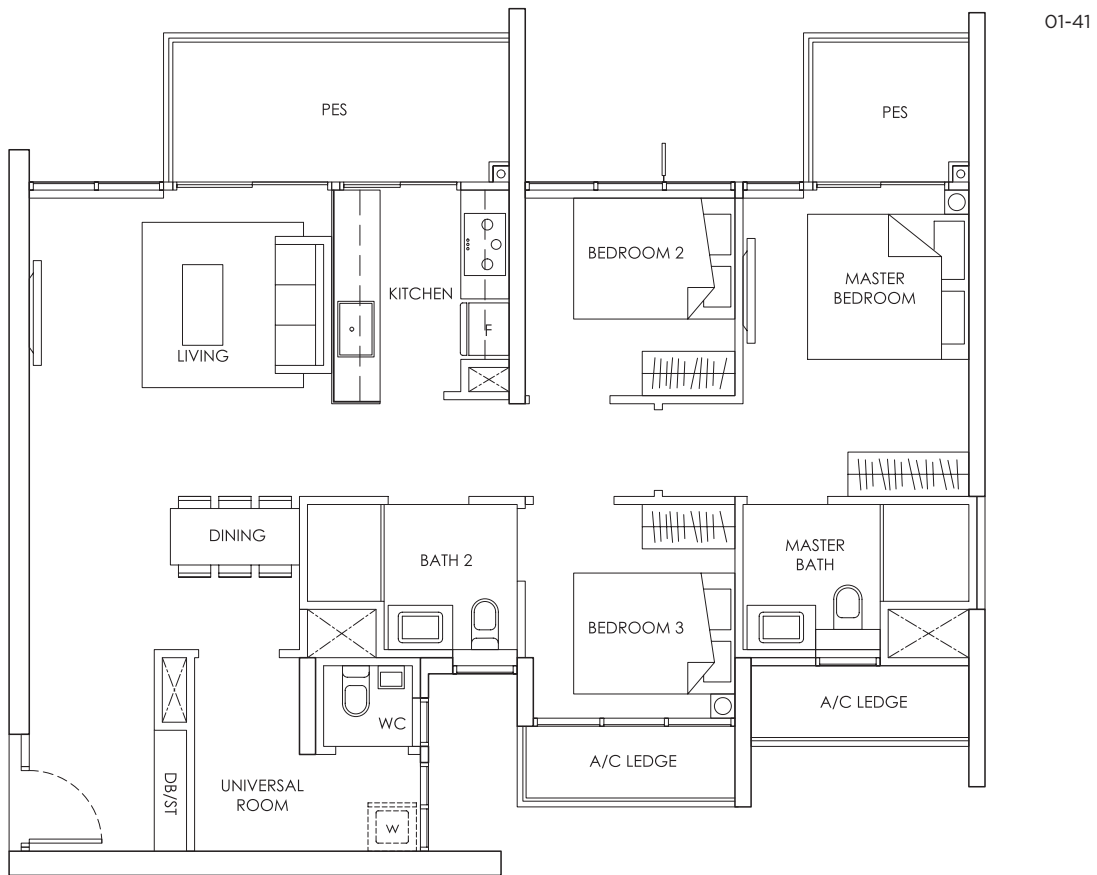
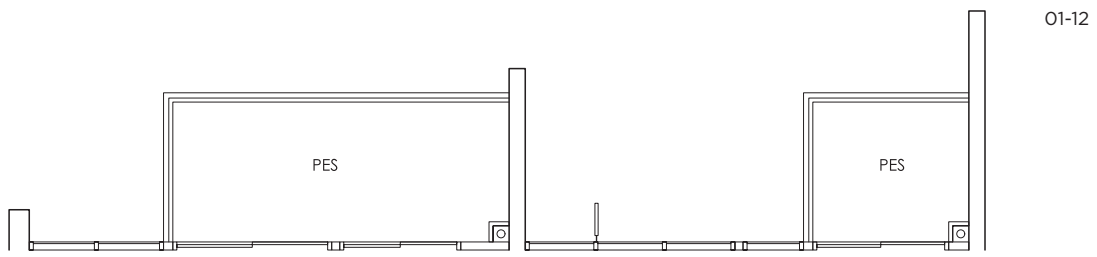

KEY PLAN

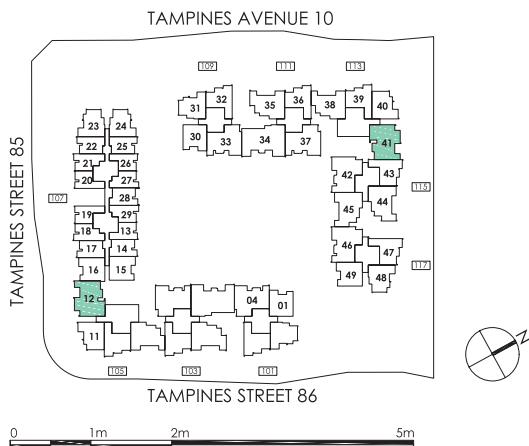

Area includes A/C ledge, balcony, PES, Roof Terrace and Void (where applicable). Orientation and facings will differ depending on the unit you are purchasing (please refer to key plan). All plans are not to scale and subject to changes as may be required by relevant authorities. All appliances and furniture shown in the plan are for illustration purpose only and not representation of fact. All floor areas are estimated and subjected to final survey.

- Legend: F - Fridge DB/ST - Distribution Board and Storage space
WC - Water Closet W - Washer cum Dryer A/C - Aircon
PES - Private Enclosed Space

TYPE D1

4 - BEDROOM 131 sqm / 1,410 sqft

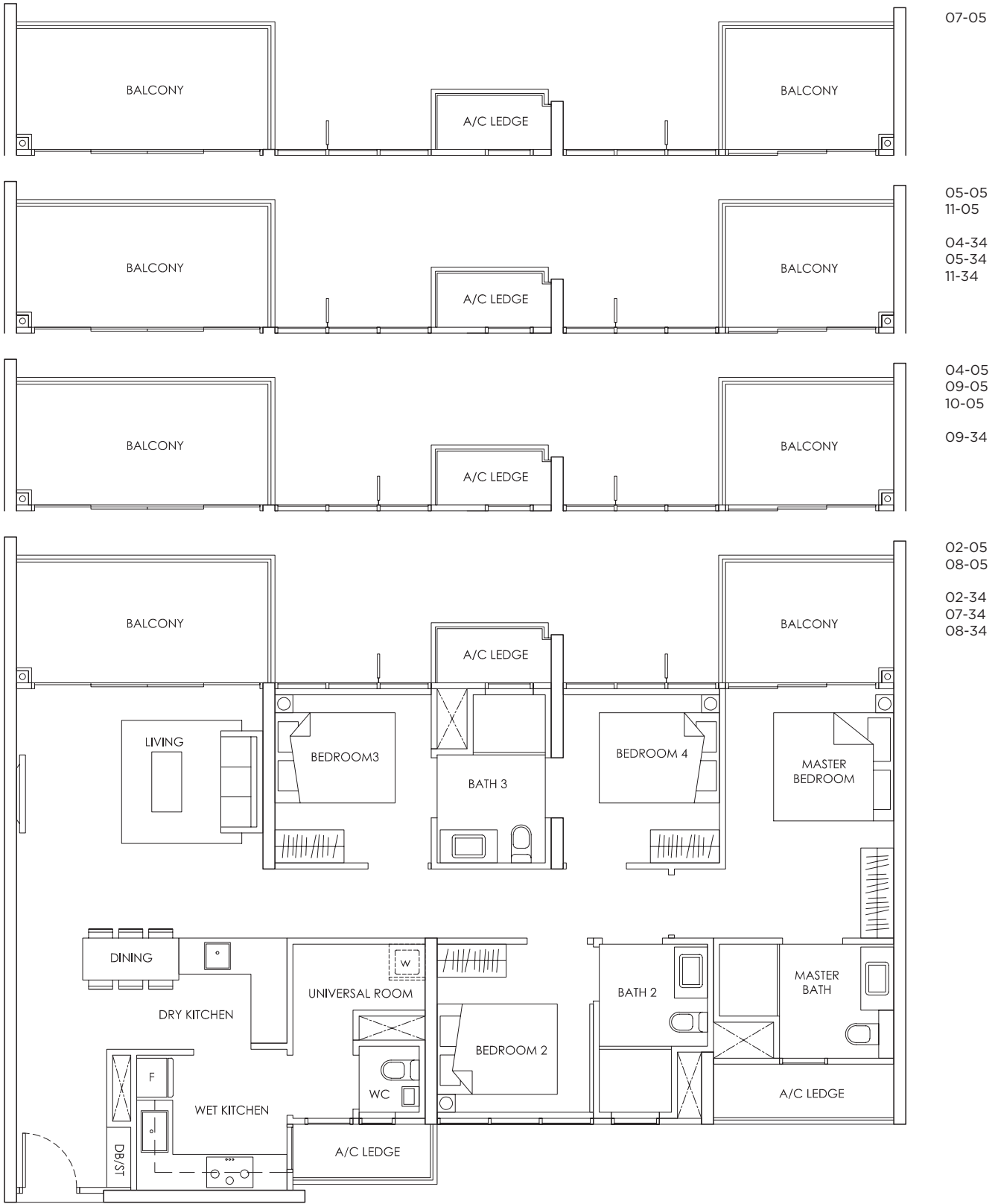

KEY PLAN

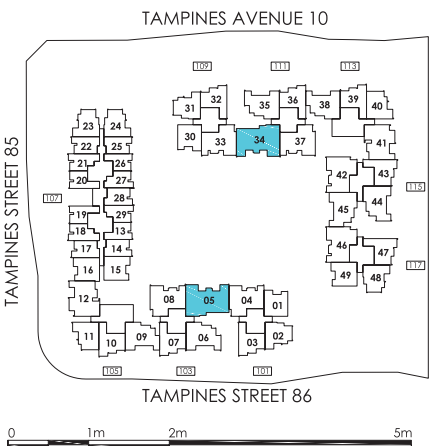

Area includes A/C ledge, balcony, PES, Roof Terrace and Void (where applicable). Orientation and facings will differ depending on the unit you are purchasing (please refer to key plan). All plans are not to scale and subject to changes as may be required by relevant authorities. All appliances and furniture shown in the plan are for illustration purpose only and not representation of fact. All floor areas are estimated and subjected to final survey.

Legend: F - Fridge DB/ST - Distribution Board and Storage space
WC - Water Closet W - Washer cum Dryer A/C - Aircon
PES - Private Enclosed Space

TYPE D1 (CONTINUED)

4 - BEDROOM 131 sqm / 1,410 sqft

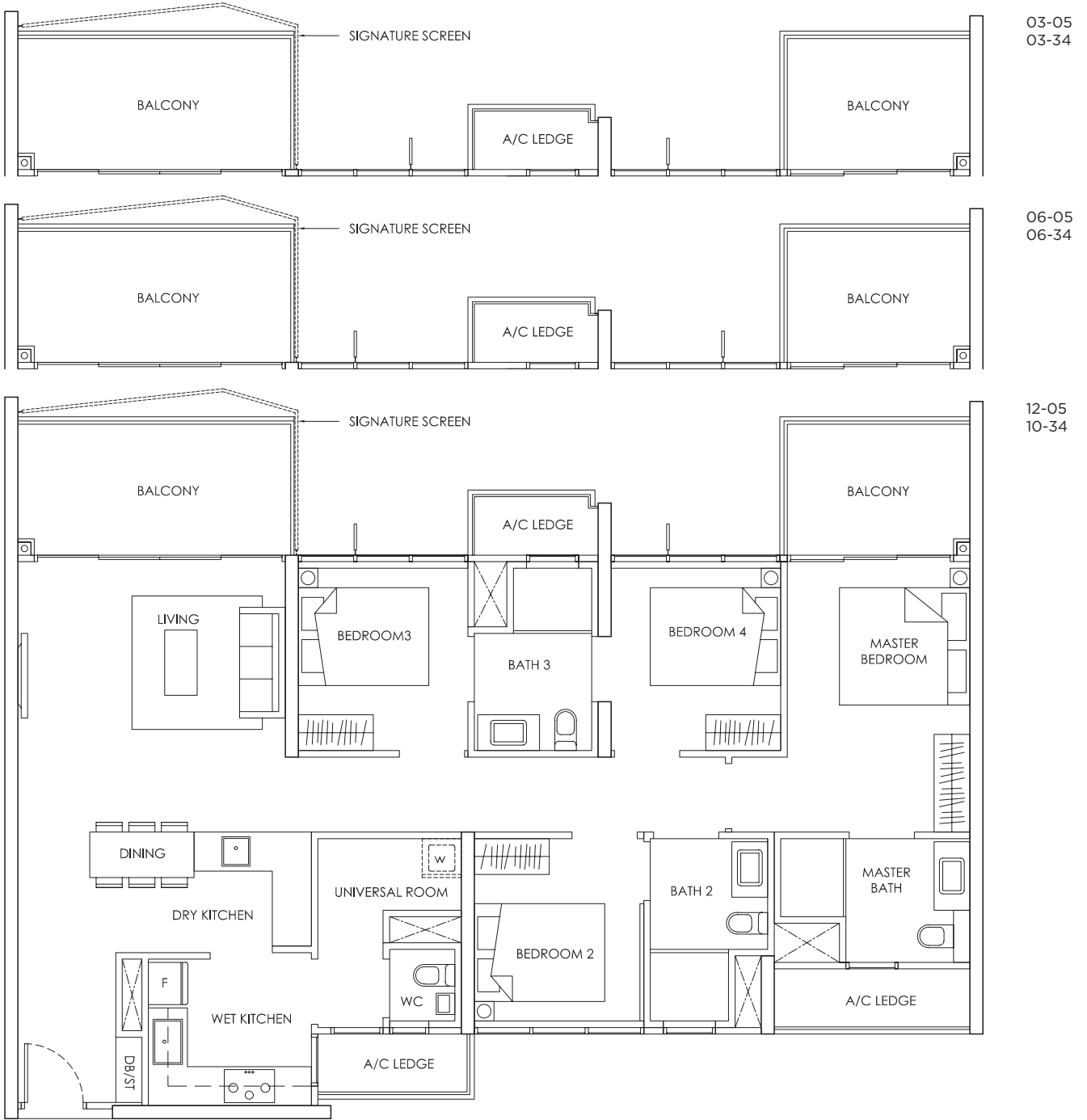

KEY PLAN

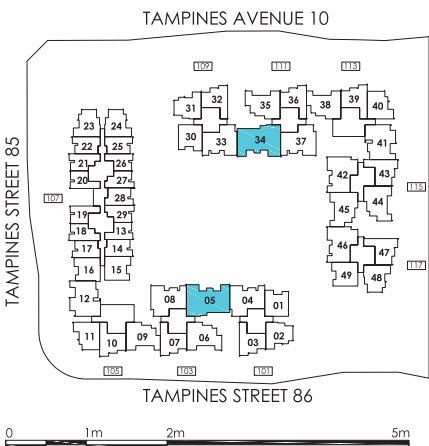

Area includes A/C ledge, balcony, PES, Roof Terrace and Void (where applicable). Orientation and facings will differ depending on the unit you are purchasing (please refer to key plan). All plans are not to scale and subject to changes as may be required by relevant authorities. All appliances and furniture shown in the plan are for illustration purpose only and not representation of fact. All floor areas are estimated and subjected to final survey.

Legend: F - Fridge DB/ST - Distribution Board and Storage space
WC - Water Closet W - Washer cum Dryer A/C - Aircon
PES - Private Enclosed Space

TYPE D1-P

4 - BEDROOM 131 sqm / 1,410 sqft



01-34

4 - BEDROOM

KEY PLAN

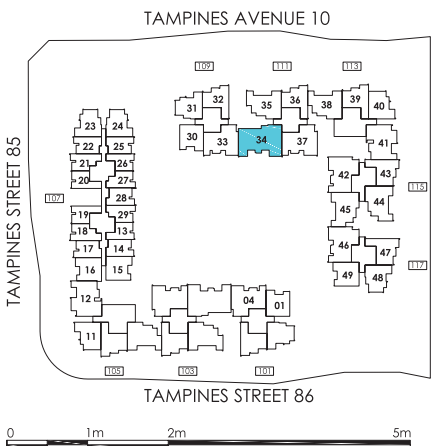

Area includes A/C ledge, balcony, PES, Roof Terrace and Void (where applicable). Orientation and facings will differ depending on the unit you are purchasing (please refer to key plan). All plans are not to scale and subject to changes as may be required by relevant authorities. All appliances and furniture shown in the plan are for illustration purpose only and not representation of fact. All floor areas are estimated and subjected to final survey.

- Legend:
- F - Fridge
 - DB/ST - Distribution Board and Storage space
 - WC - Water Closet
 - W - Washer cum Dryer
 - A/C - Aircon
 - PES - Private Enclosed Space

[Click To Siteplan](#)



PENTHOUSES

TYPE PHI

4 - BEDROOM
155 sqm / 1,668 sqft

[Click To Siteplan](#)

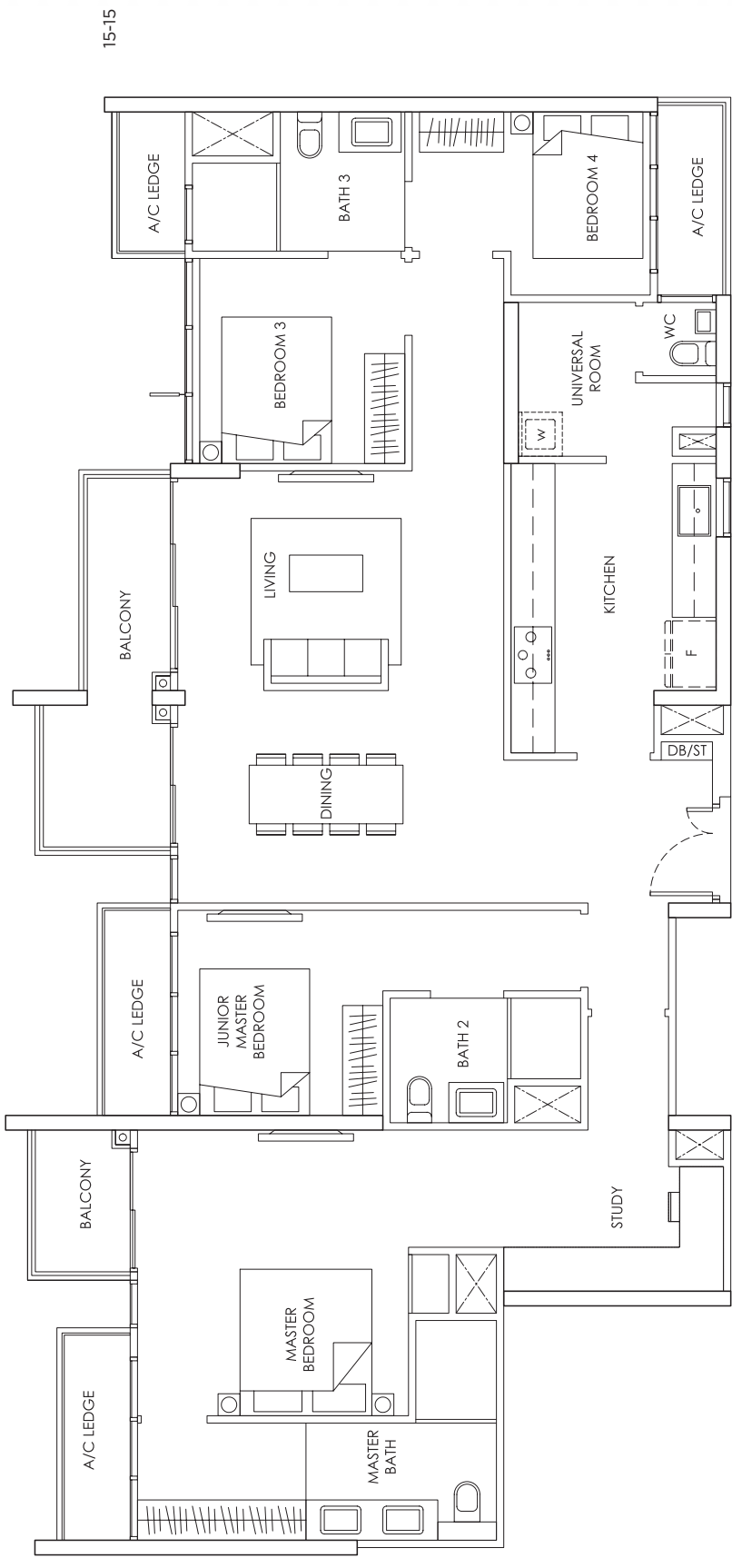

Area includes A/C ledge, balcony, PES, Roof Terrace and Void (where applicable). Orientation and facings will differ depending on the unit you are purchasing (please refer to key plan). All plans are not to scale and subject to changes as may be required by relevant authorities. All appliances and furniture shown in the plan are for illustration purpose only and not representation of fact. All floor areas are estimated and subjected to final survey.

Legend: **F** - Fridge **DB/ST** - Distribution Board and Storage space **WC** - Water Closet **W** - Washer cum Dryer **A/C** - Aircon **PES** - Private Enclosed Space

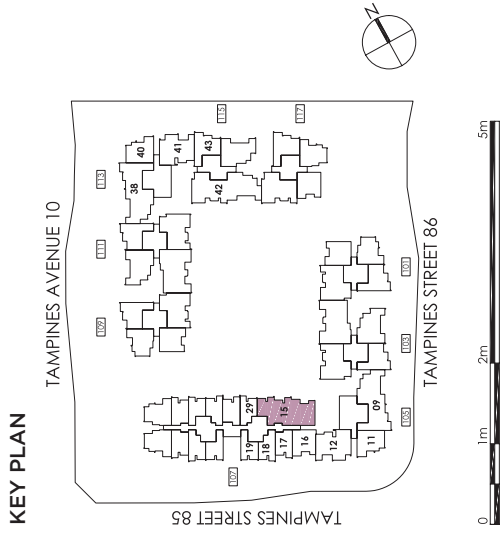

15-09,
15-38

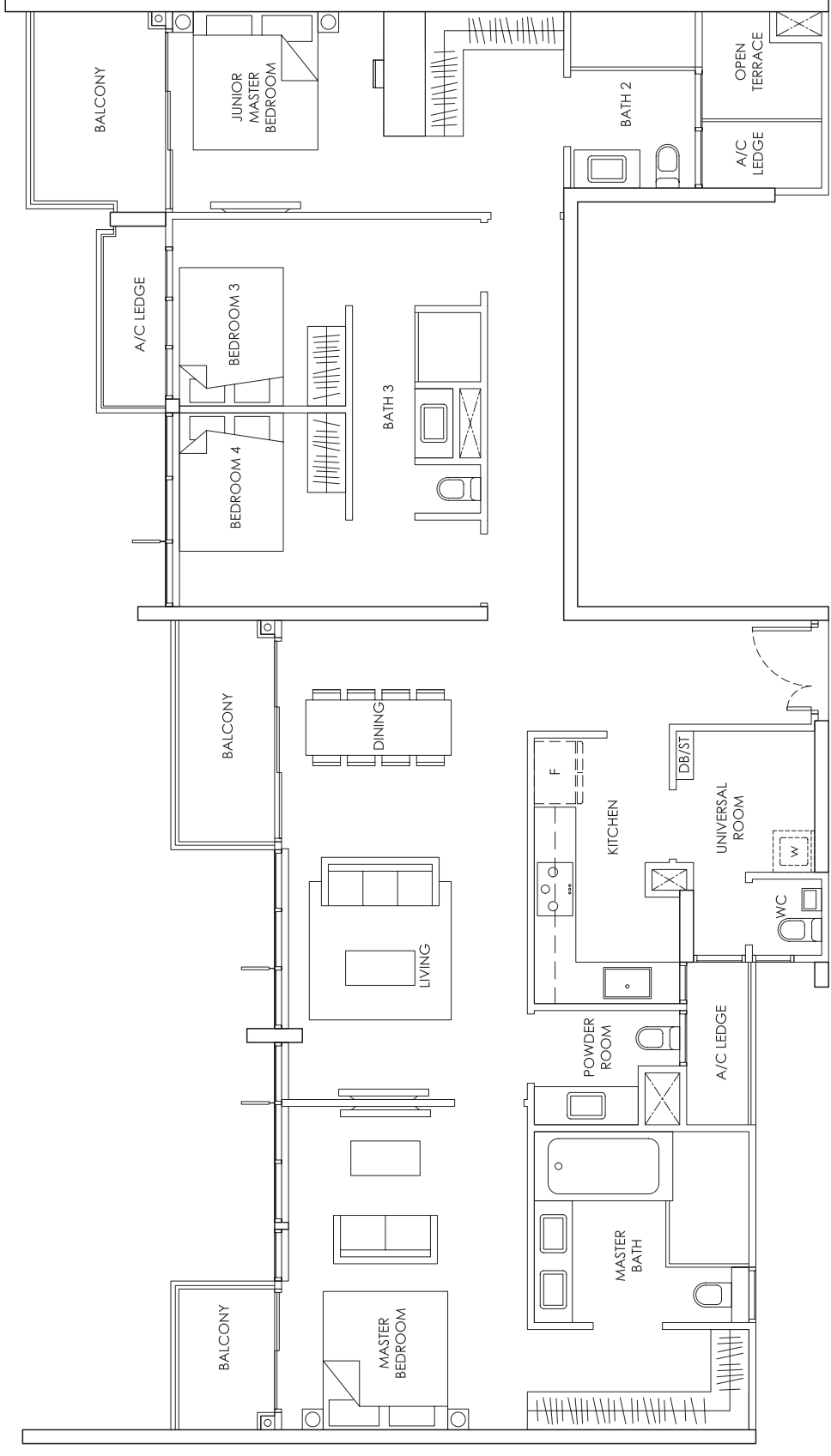

Area includes A/C ledge, balcony, PES, Roof Terrace and Void (where applicable). Orientation and facings will differ depending on the unit you are purchasing (please refer to key plan). All plans are not to scale and subject to changes as may be required by relevant authorities. All appliances and furniture shown in the plan are for illustration purpose only and not representation of fact. All floor areas are estimated and subjected to final survey.

Legend: **F** - Fridge **DB/ST** - Distribution Board and Storage space **WC** - Water Closet **W** - Washer cum Dryer **A/C** - Aircon **PES** - Private Enclosed Space

TYPE PH2

4 - BEDROOM
165 sqm / 1,776 sqft

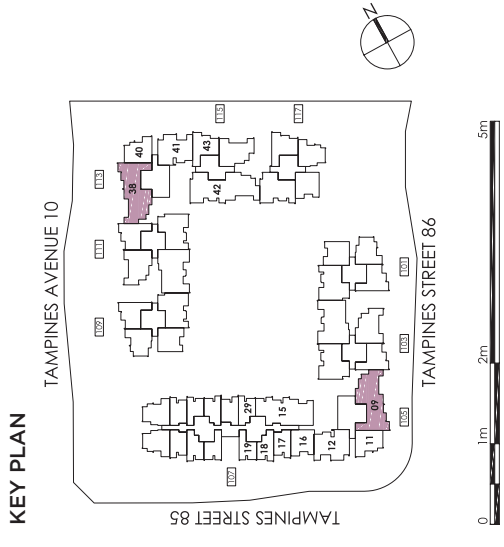

TYPE PH3

4 - BEDROOM
194 sqm / 2,088 sqft

[Click To Siteplan](#)

15-42

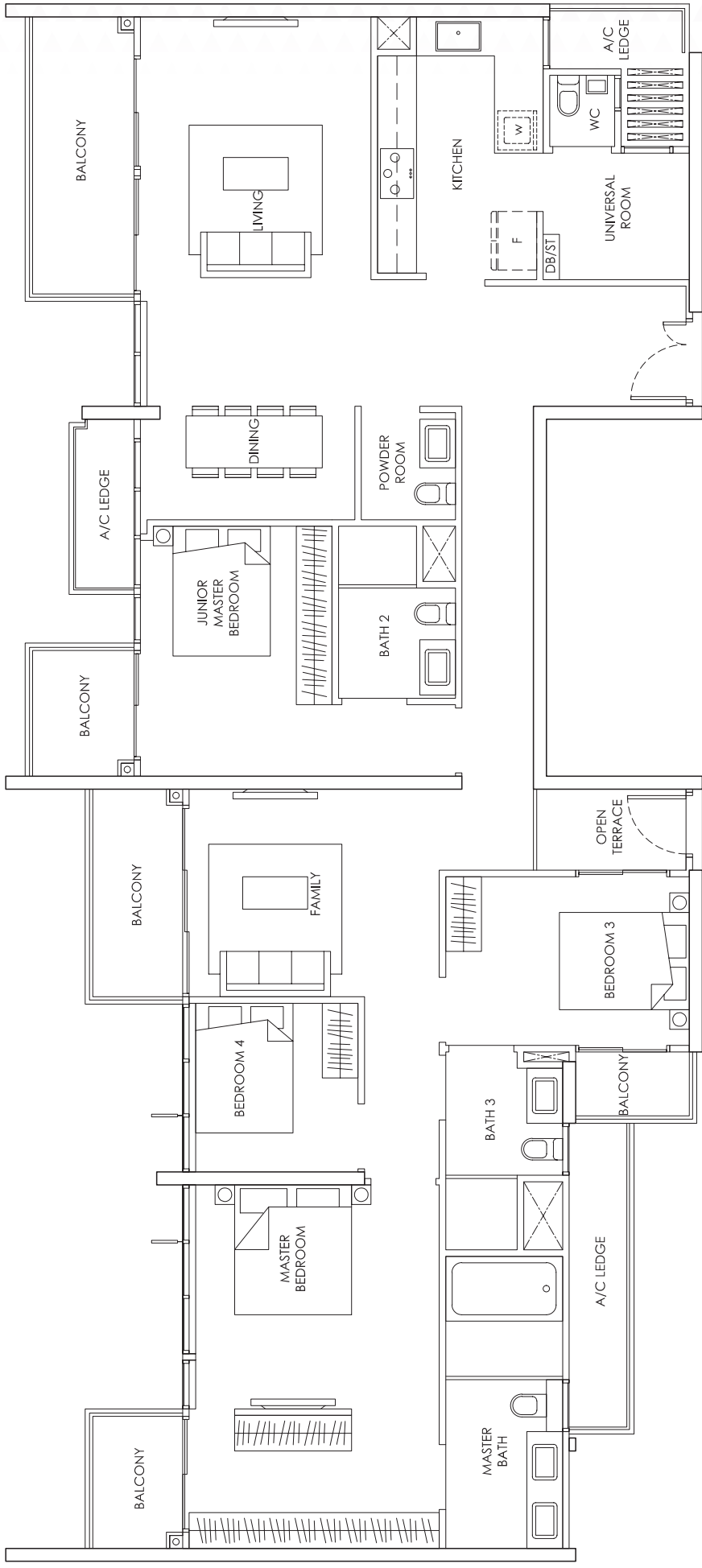

Area includes A/C ledge, balcony, PES, Roof Terrace and Void (where applicable). Orientation and facings will differ depending on the unit you are purchasing (please refer to key plan). All plans are not to scale and subject to changes as may be required by relevant authorities. All appliances and furniture shown in the plan are for illustration purpose only and not representation of fact. All floor areas are estimated and subjected to final survey.

Legend: **F** - Fridge **DB/ST** - Distribution Board and Storage space **WC** - Washer cum Dryer **W** - Water Closet **A/C** - Aircon **PES** - Private Enclosed Space

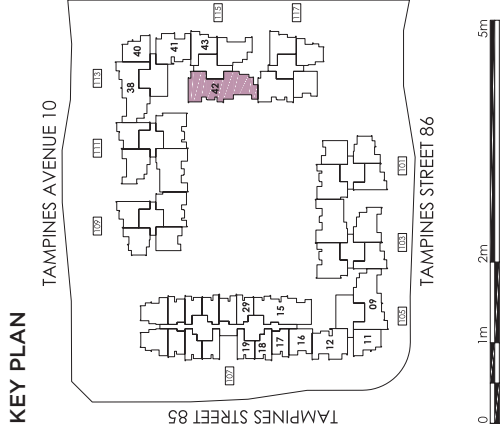

TYPE PH4

5 - BEDROOM +
STUDY
231 sqm / 2,486 sqft

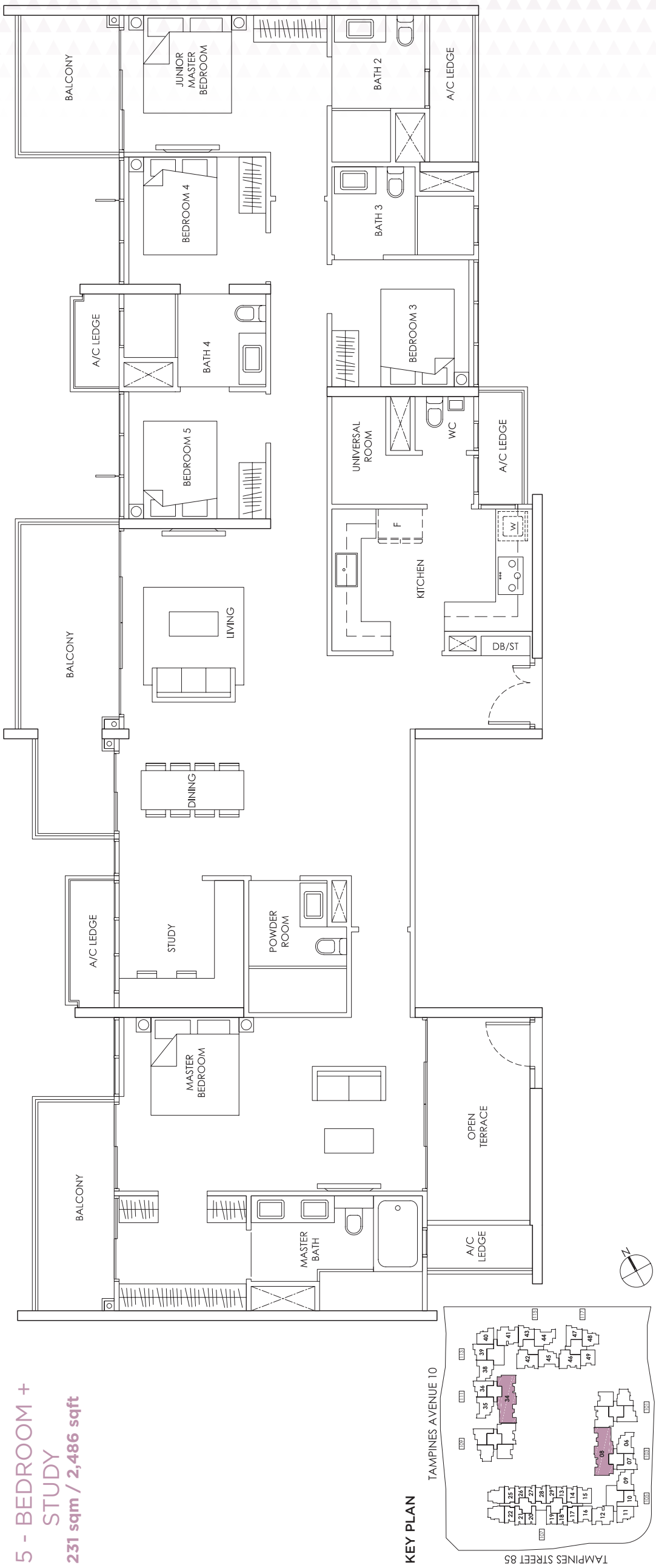

Area includes A/C ledge, balcony, PES, Roof Terrace and Void (where applicable). Orientation and facings will differ depending on the unit you are purchasing (please refer to key plan). All plans are not to scale and subject to changes as may be required by relevant authorities. All appliances and furniture shown in the plan are for illustration purpose only and not representation of fact. All floor areas are estimated and subjected to final survey.

Legend: **F** - Fridge **DB/ST** - Distribution Board and Storage space **WC** - Water Closet **W** - Washer cum Dryer **A/C** - Aircon **PES** - Private Enclosed Space

ABOUT MCC LAND

MCC Land (Singapore) Pte Ltd (the “Company”), a subsidiary of Metallurgy Corporation of China Ltd listed in Hong Kong and Shanghai Exchange, is a developer and engineering services provider in Singapore. A Fortune Global 500 company, the Company has been instrumental in shaping the city landscape of Singapore by being involved in the building of numerous notable landmarks, including Universal Studios at Resorts World Sentosa, the Keppel Distripark and HDB BTO projects. In recent times, the Company has developed and/or managed a number of quality housing projects from executive condominiums to private condominiums, such as The Canopy, The Nautical, Canberra Residences, One Canberra, Forestville and The Santorini to name a few. Since 2010, MCC Land (Singapore) Pte Ltd has launched a total of 4,910 private condominium and executive condominium units*, with another 1,362 units in the pipeline. We aim to create inspiring lifestyles and landscapes that will propel Singapore into a 21st century global city.

* including projects it develops and where it project manages for other developers.

Developed by



THE POIZ RESIDENCES & CENTRE, SINGAPORE



THE SANTORINI, SINGAPORE

 **WHATSAPP**
 **WECHAT**
8338 7800

www.thealpsresidences.com.sg

